

# Heller

# JAGUAR TYPE E 3L8 FHC

## 80709



# DÉCOUVREZ LE MONDE DES PEINTURES ACRYLIQUES HELLER !

DISCOVER THE WORLD OF HELLER ACRYLIC PAINTS!  
ENTDECKEN SIE DIE WELT DER HELLER ACRYL-FARBEN!



**NEW**

- FACILE À UTILISER
- DILUABLE À L'EAU
- POTS DE PEINTURE STABLES
- BOUCHON À VIS SÉCURISÉ
- EASY TO USE
- DILUTABLE WITH WATER
- STABLE PAINT CANS
- SECURE SCREW CAP
- EINFACHE ANWENDUNG
- MIT WASSER VERDÜNNBAR
- STANDFESTE FARBDOSEN
- SICHERER SCHRAUBVERSCHLUSS

## Français

La Jaguar type E fit son apparition en 1961 au salon de Genève. Elle succédait à la XK120 de douze ans son aînée. Après les deux premiers prototypes, qui étaient des cabriolets deux places, Jaguar développa la E1A (A pour aluminium). La voiture était motorisée par un six cylindres et fut déclinée en coupé ou cabriolet, puis en 2+2 à partir de 1966. Le coupé deux places fut définitivement abandonné à partir de la série 3 (1971-1975). La série 1 se caractérise par ses phares carénés, ses demi pare-chocs et un tableau de bord « type aviation ».

La Jaguar fut engagée en compétition, notamment avec Briggs Cunningham au volant assisté de Roy Salvadori en 1962 (4e au Mans), et en 1963 (9e) avec Bob Grossman.

A sa sortie la Jaguar type E était la voiture de production la plus rapide du monde, frôlant les 250 km/h. Plus de 72500 exemplaires ont été construits.

En 2010, la marque au félin a fêté son soixante quinzième anniversaire, et fut célébrée partout dans les clubs de collectionneurs.

## English

The Jaguar E-Type was introduced at the 1961 Geneva Motor Show. It followed the XK120, twelve years its senior. After the first two prototypes, which were two-seat convertible, Jaguar developed the E1A (A for aluminium). The car was powered by a six cylinder engine and was first available as either as a two-door sedan or convertible, and then as a 2+2 door model as of 1966. The two-seat sedan was definitively withdrawn as of series 3 (1971-1975). The Series 1 was characterised by its glass-covered headlights, half-bumpers and an aircraft-style dashboard.

The Jaguar was raced competitively, in particular in 1962 with Briggs Cunningham at the wheel, assisted by Roy Salvadori (4th at the 24 Hours of Le Mans), and in 1963 (9th) with Bob Grossman.

Upon its release, the Jaguar E-Type was the world's fastest production car, with a top speed approaching 250 km/hr. More than 72,500 units were built.

In 2010, the feline brand celebrated its seventy-fifth anniversary, which was widely celebrated by collectors' clubs.

<b>Empattement</b>	243 cm
<b>Voie avant et arrière</b>	126 cm
<b>Longueur</b>	437 cm
<b>Largeur</b>	162 cm
<b>Moteur</b>	6 cylindres, 3,8 litres
<b>Puissance</b>	265 cv
<b>Suspension</b>	indépendante aux quatre roues
<b>Freins</b>	Dunlop à disque pour chaque roue
<b>Pneumatiques</b>	Dunlop 6,40 X 15 RS5
<b>Vitesse maximale</b>	255 km/h

<b>Wheelbase</b>	243 cm
<b>Front and rear track</b>	126 cm
<b>Length</b>	437 cm
<b>Width</b>	162 cm
<b>Engine</b>	six cylinders, 3.8 liters
<b>Power</b>	265 hp
<b>Suspension</b>	independent on all four wheels
<b>Brakes</b>	Dunlop disc brakes on all four wheels
<b>Tires</b>	Dunlop 6.40 x 15 RS5
<b>Top speed</b>	255 km/h (160 mph)

## Deutsch

Der Jaguar E-Type erschien erstmalig auf dem Genfer Auto-Salon 1961. Er folgte auf seinen großen Bruder XK120 mit zwölf Jahren Abstand. Nach zwei ersten Prototypen, die zweiseitige Cabriolets waren, entwickelte Jaguar den E1A (A für Aluminium). Das Fahrzeug war mit sechs Zylindern motorisiert und wurde als Coupé oder Cabriolet abgesetzt, danach ab 1966 mit 2+2 Sitzen. Das Coupé mit zwei Sitzen wurde ab der Serie 3 (1971 – 1975) definitiv eingestellt. Typisch für die Serie 1 waren die stromlinienförmigen Scheinwerfer, die zweiteiligen Stoßfänger und das Armaturenbrett in „Flugzeugoptik“.

Jaguar engagierte sich im Sport, insbesondere 1962 mit Briggs Cunningham am Steuer und Roy Salvadori als Partner (4. Platz in Le Mans) und 1963 (9. Platz) mit Bob Grossmann.

Bei Erscheinen war der Jaguar E-Type der schnellste Serienwagen der Welt, der bis zu 250 km/h erreichen konnte. Es wurden mehr als 72.500 Exemplare gebaut.

2010 feierte die Marke mit der Raubkatze ihren 75. Geburtstag und ließ sich weltweit in Sammlerclubs feiern.

## Español

El Jaguar E-type hizo su aparición en 1961 en el salón del automóvil de Ginebra. Sería el sucesor del modelo XK120, lanzado al mercado doce años antes. Tras los dos primeros prototipos (cabriolé biplaza), Jaguar desarrollaría el E1A (A como abreviatura de aluminio). El vehículo poseía un motor de seis cilindros y estaba disponible en carrocerías tipo cupé o cabriolé. Más tarde, en 1966, se incluiría la carrocería tipo 2 cuerpos. El modelo biplaza cupé dejaría definitivamente de fabricarse a partir de la serie 3 (1971 a 1975). La serie 1 se caracteriza por sus faros integrados en la carrocería y protegidos por una cubierta transparente, parachoques divididos en dos secciones y un tablero de instrumentos de "estilo aeronáutico".

El Jaguar participó activamente en competiciones automovilísticas; en particular, de la mano del piloto Briggs Cunningham y copiloto Roy Salvadori en 1962 (4ª posición en Le Mans) y del piloto Bob Grossman en 1963 (9ª posición).

En el momento de su lanzamiento, el Jaguar E-type era el vehículo de serie más rápido del mundo, rondando una velocidad de 250 km/h. Llegaron a fabricarse más de 72 500 unidades.

En 2010, marca del felino cumpliría su 75 aniversario, que sería celebrado por clubes de coleccionista de todo el mundo.

## Italiano

La Jaguar E-Type fece il suo debutto nel 1961, al Salone di Ginevra. Sostituì la XK120, di dodici anni più vecchia. Dopo i due primi prototipi, delle cabriolet a due posti, la Jaguar sviluppò la E1A (A come alluminio). La vettura montava un motore a sei cilindri e fu declinata in versione coupé e cabriolet, quindi, a partire dal 1966, in versione 2+2. La coupé a due posti fu definitivamente abbandonata a partire dalla serie 3 (1971-1975). La serie 1 è caratterizzata da fari carenati, semi paraurti e un cruscotto "da aviazione".

La Jaguar partecipò a diverse competizioni, in particolare con Briggs Cunningham al volante assistito da Roy Salvadori nel 1962 (4° a Le Mans), e nel 1963 (9°) con Bob Grossman.

Alla sua uscita, la Jaguar E-Type era la vettura turismo più veloce del mondo, sfiorando i 250 km/h. Furono costruiti oltre 72 500 esemplari.

Nel 2010, il marchio del giaguaro rampante ha festeggiato il suo settantacinquesimo anniversario, celebrato ovunque dai collezionisti.

## Nederlands

De Jaguar type E werd in 1961 voor het eerst voorgesteld op het salon van Genève. Ze volgde de twaalf jaar oudere XK120 op. Na de twee eerste prototypes, die cabriolets met twee plaatsen waren, ontwikkelde Jaguar de E1A (A voor aluminium). De wagen was uitgerust met een motor van zes cilinders en kwam als coupé of cabriolet, en vanaf 1966 als 2+2, op de markt. De coupé met twee plaatsen werd vanaf de serie 3 (1971-1975) niet langer gebouwd. De serie 1 kenmerkte zich door de gestroomlijnde koplampen, de halve bumper en een "vliegtuig" dashboard.

De Jaguar nam deel aan wedstrijden, met in het bijzonder Briggs Cunningham aan het stuur en bijgestaan door Roy Salvadori in 1962 (4e in Mans) en door Bob Grossman in 1963 (9e).

Toen de Jaguar type E op de markt kwam was ze de snelste productiewagen ter wereld, met snelheden tot 250 km/u. Er werden meer dan 72500 stuks gebouwd.

In 2010 heeft het merk met de wilde kat haar vijfenzeventigste verjaardag gevierd en is ze vermaard bij verzamelaars over de hele wereld.

<b>Radstand</b>	243 cm
<b>Spur vorne und hinten</b>	126 cm
<b>Länge</b>	437 cm
<b>Breite</b>	162 cm
<b>Motor</b>	6-Zylinder; 3,8 Liter
<b>Leistung</b>	265 PS
<b>Aufhängung</b>	unabhängig an allen vier Räder
<b>Bremsen</b>	Dunlop Scheibenbremsen an allen Rädern
<b>Bereifung</b>	Dunlop 6,40 x 15 RS5
<b>Spitzengeschwindigkeit</b>	255 km/h

<b>Distancia entre ejes</b>	243 cm
<b>Distancia entre ruedas delante y atrás</b>	126 cm
<b>Longitud</b>	437 cm
<b>Ancho</b>	162 cm
<b>Motor</b>	seis cilindros, 3,8 litros
<b>Potencia</b>	265 HP
<b>Suspensión</b>	independiente en las cuatro ruedas
<b>Frenos</b>	Dunlop de disco para cada rueda
<b>Neumáticos</b>	Dunlop 6,40 X 15 RS5
<b>Velocidad máxima</b>	255 km/h

<b>Interasse</b>	243 cm
<b>Carreggiata anteriore e posteriore</b>	126 cm
<b>Lunghezza</b>	437 cm
<b>Larghezza</b>	162 cm
<b>Motore</b>	6 cilindres, 3,8 litres
<b>Potenza</b>	265 CV
<b>Sospensione</b>	indipendente per le 4 ruote
<b>Freni</b>	Dunlop a disco per ogni ruota
<b>Pneumatici</b>	Dunlop 6,40 X 15 RS5
<b>Velocità massima</b>	255 km/h

<b>Wielbasis</b>	243 cm
<b>Voor en achter spoor</b>	126 cm
<b>Lengte</b>	437 cm
<b>Breedte</b>	162 cm
<b>Motor</b>	zes cilinders, 3,8 liter
<b>Vermogen</b>	265 PK
<b>Ophanging</b>	onafhankelijk voor vier wielen
<b>Remmen</b>	Dunlop met schijf voor elk wiel
<b>Banden</b>	Dunlop 6,40 X 15 RS5
<b>Maximale snelheid</b>	255 km/u

2

Numéro de phase  
Step number  
Schrittnummer  
Número de fase

56

Référence de couleur  
Colour reference no  
Farbangabe  
Referencia de color





37

Numéro de pièce  
Part number  
Teilenummer  
Número de pieza

6

Numéro de decal  
Decal number  
Nummer von Abziehbild  
Número de calcomanía

PEINTURES ESSENTIELLES / ESSENTIAL PAINTS

-   
**9**  
 Marron clair brillant  
 Gloss Tan  
 Glänzend-Holzbraun
-   
**11**  
 Argent  
 Silver  
 Silber
-   
**19**  
 Rouge vif brillant  
 Gloss bright red  
 Glänzend-Hellrot
-   
**53**  
 Gris métallique  
 Gunmetal  
 Metallgrau
-   
**85**  
 Noir satiné  
 Satin black  
 Seidenmatt-Schwarz
-   
**127**  
 Gris satiné  
 Satin grey  
 Satin Grau

PEINTURES COMPLEMENTAIRES / ADDITIONAL PAINTS

Disponibles séparément chez votre revendeur de maquettes. / Available separately at you local hobby shop.

-   
**21**  
 Noir brillant  
 Gloss black  
 Glänzend-Schwarz
-   
**33**  
 Noir mat  
 Matt black  
 Matt-Schwarz
-   
**56**  
 Aluminium  
 Aluminium  
 Aluminium
-   
**62**  
 Cuir mat  
 Matt leather  
 Matt-Leder
-   
**66**  
 Gris olive mat  
 Matt olive drab  
 Matt-Olivgrün
-   
**321**  
 Rouge transparent  
 Clear red  
 Durchsichtiges Ro
-   
**322**  
 Orange transparent  
 Clear orange  
 Durchsichtiges Orange

**1**  **x4**

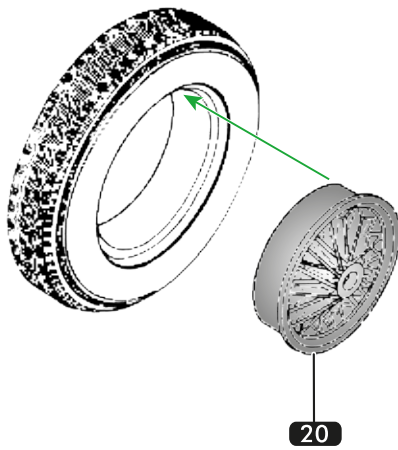

**20**

**2** 

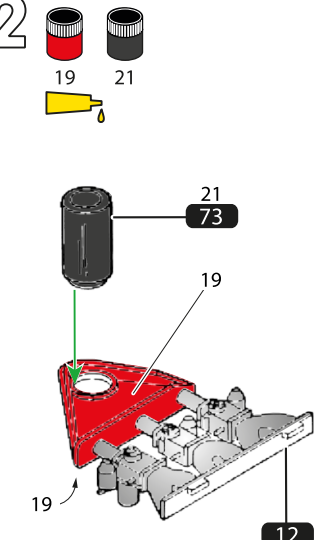

**19** **21**

**21** **73**

**19** **12**

**3** 

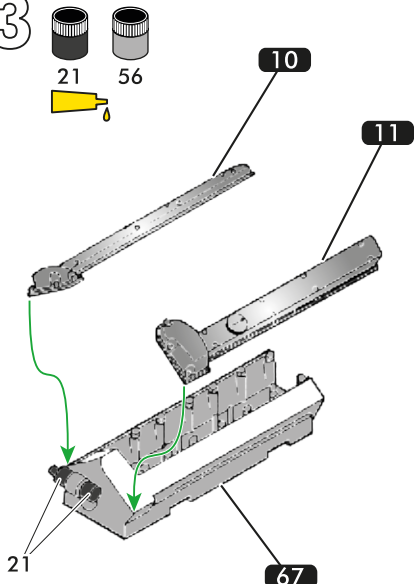

**21** **56**

**10** **11**

**21** **67**

**4** 

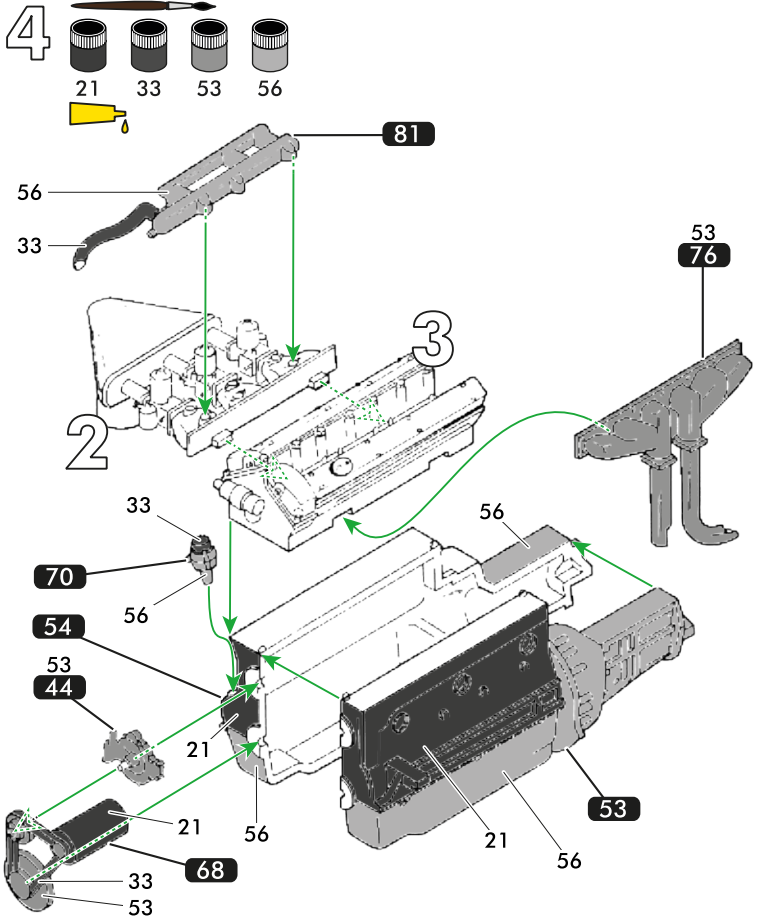

**21** **33** **53** **56**

**81**

**56** **33**

**3**

**53** **76**

**2**

**33**

**70** **56**

**54** **56**

**53** **44**

**21**

**53**

**21** **56**

**68** **33** **53**

**5** 

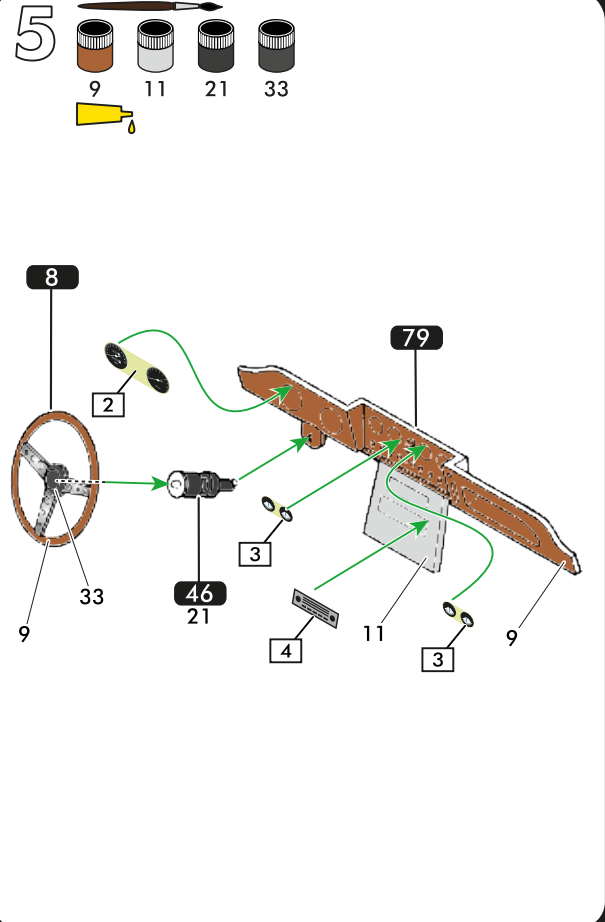

**9** **11** **21** **33**

**8**

**2**

**33**

**79**

**3**

**46** **21**

**11** **3**

**9**





# 12

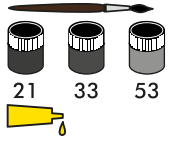

Riveter  
To rivet  
Nieten  
Remachar

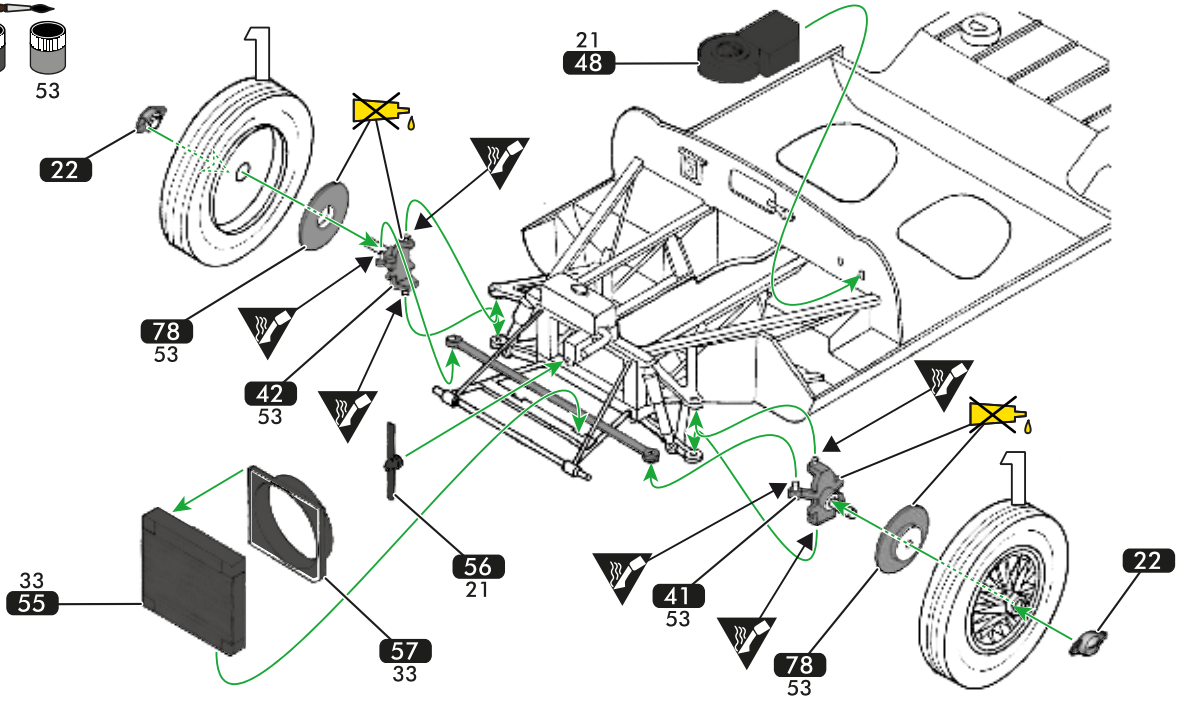

# 13

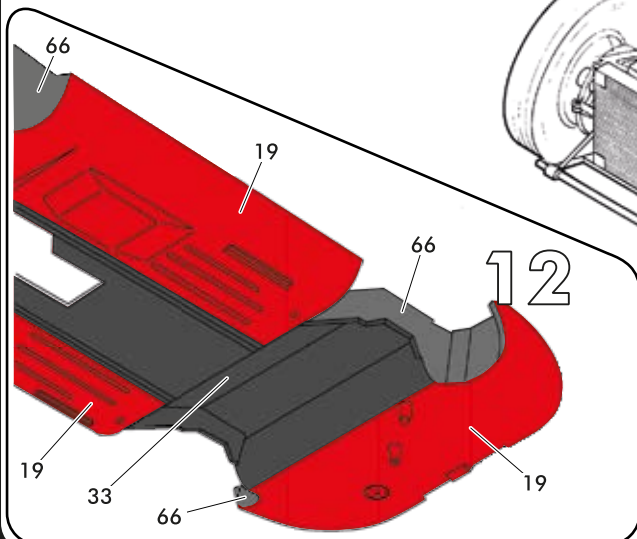
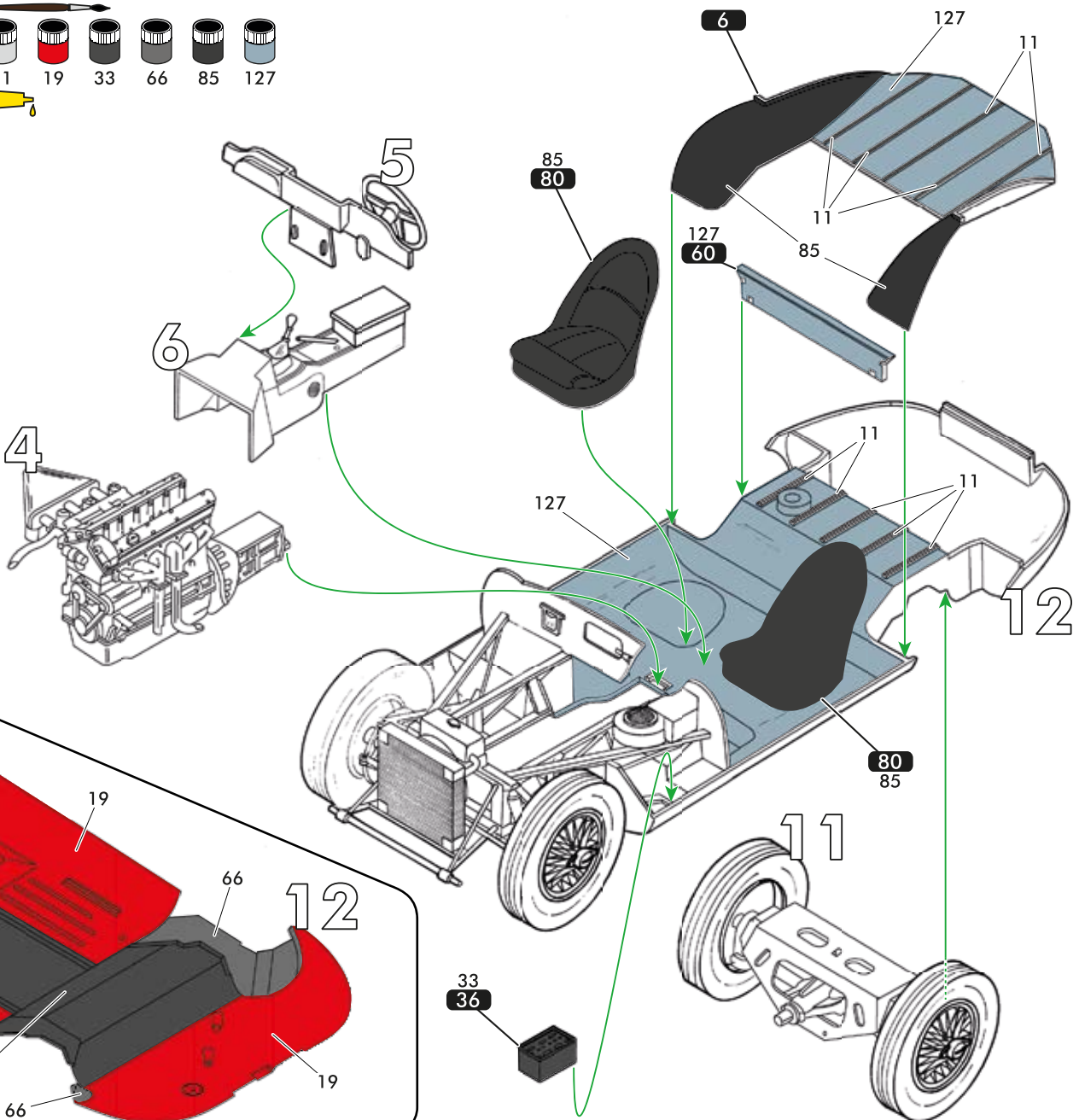
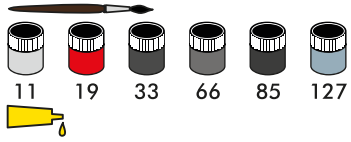

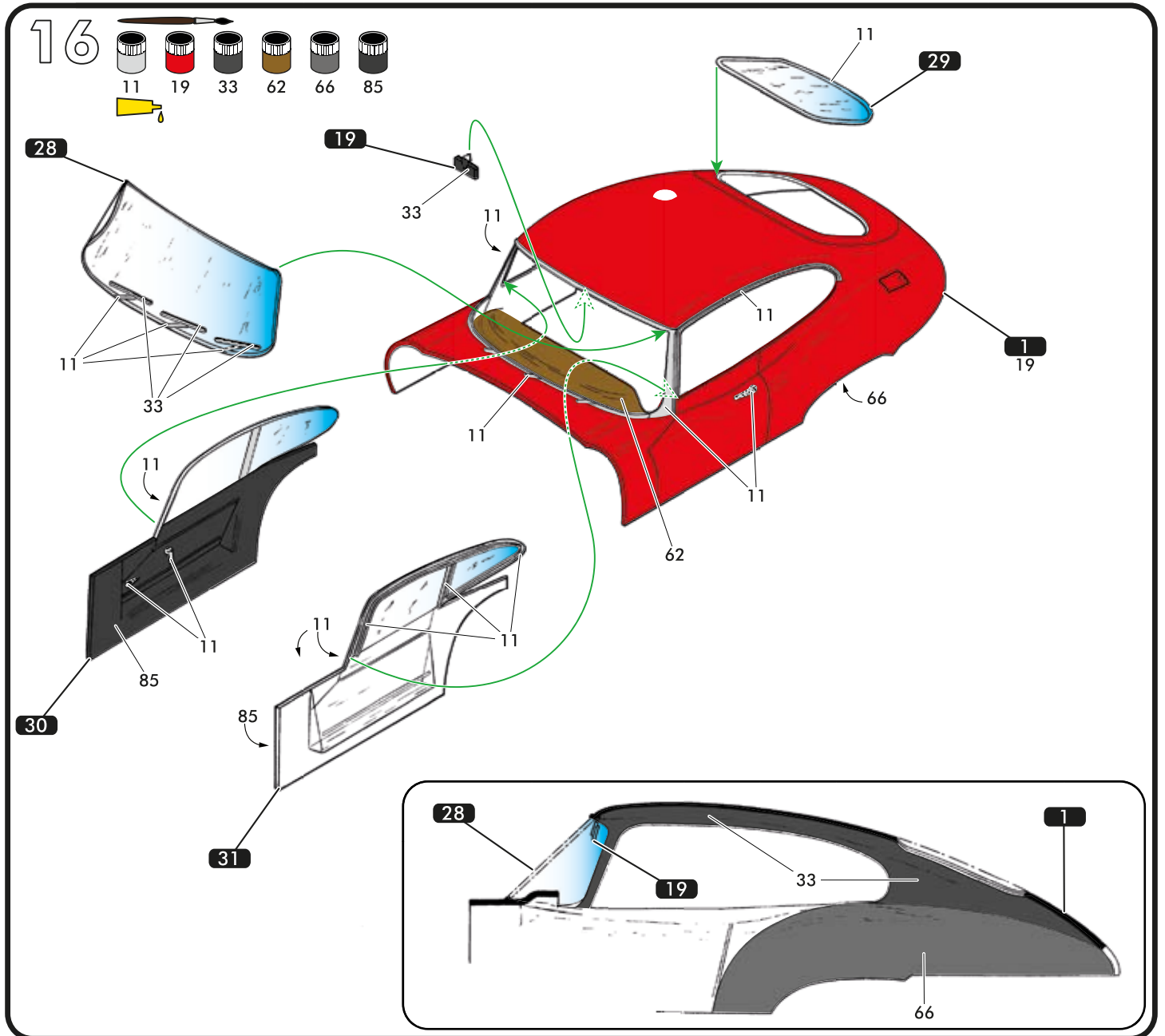
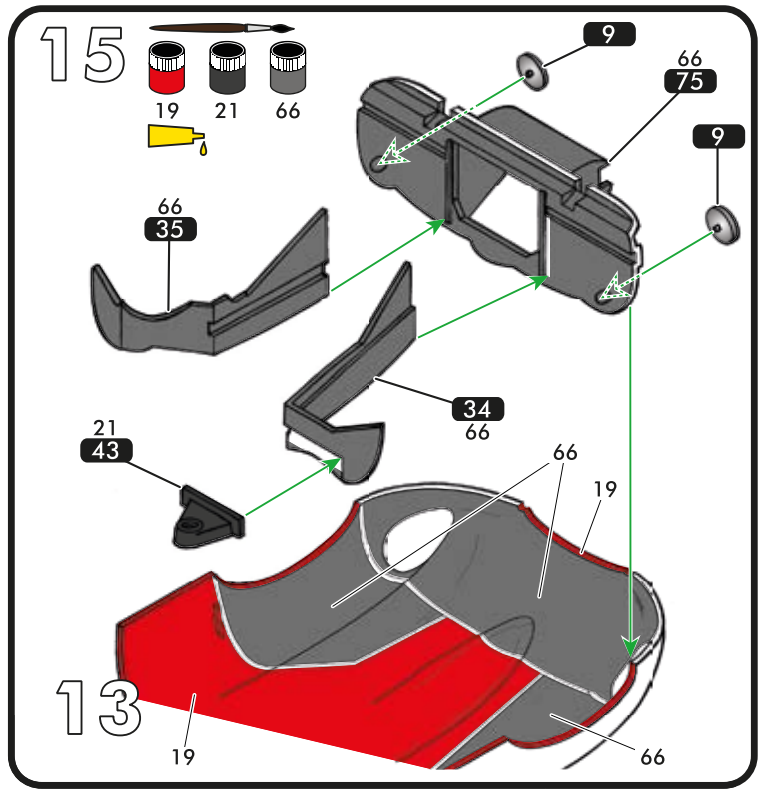
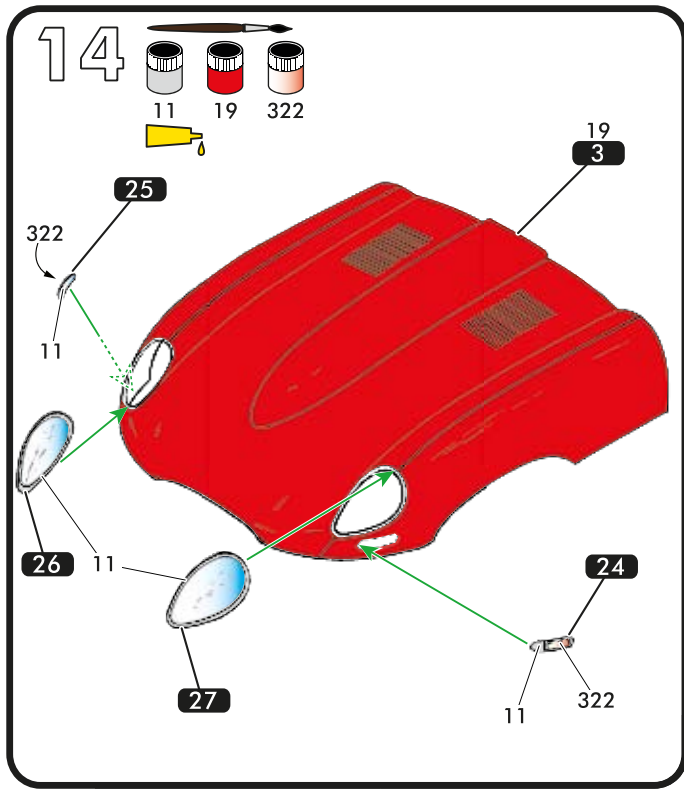



17

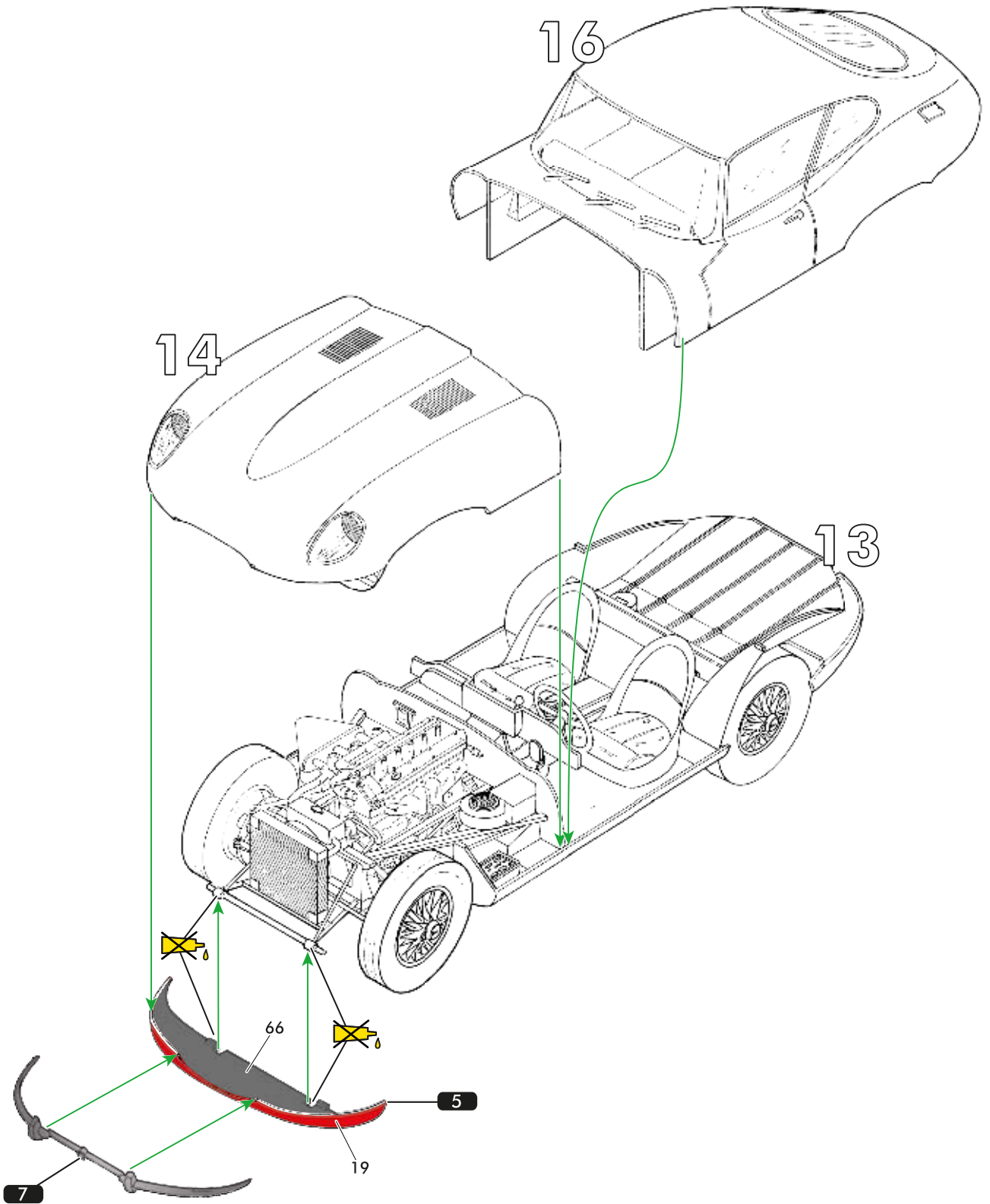
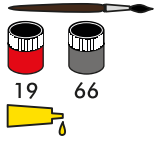



# 18

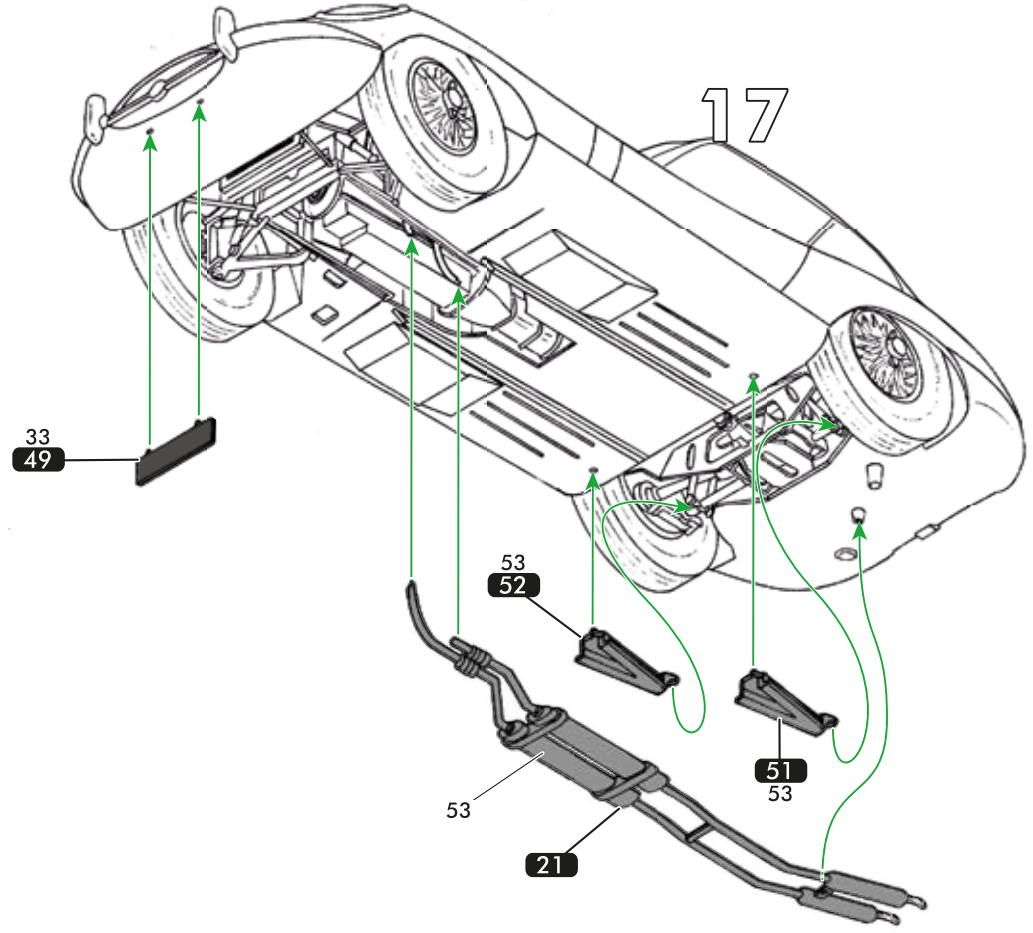
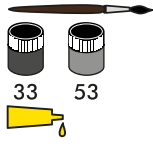

# 19

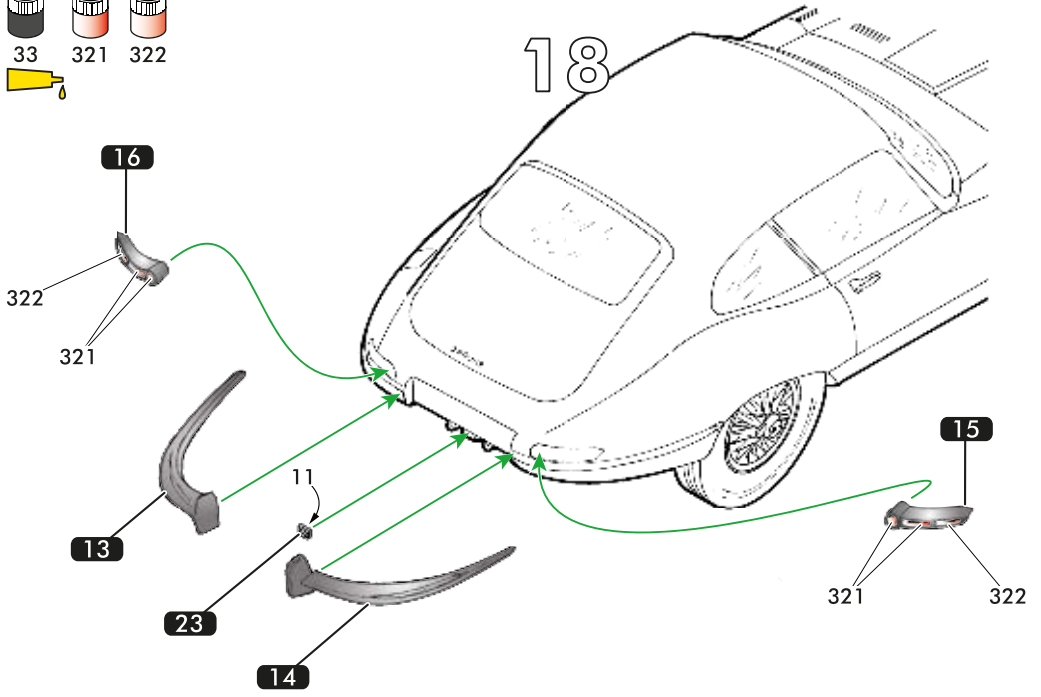
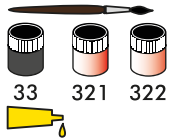

20

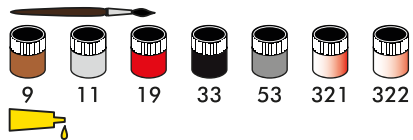

### JAGUAR TYPE E 3L8 FHC 1963

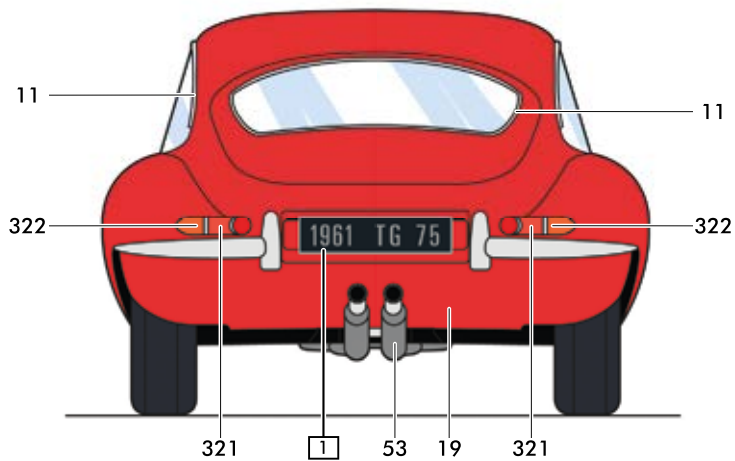
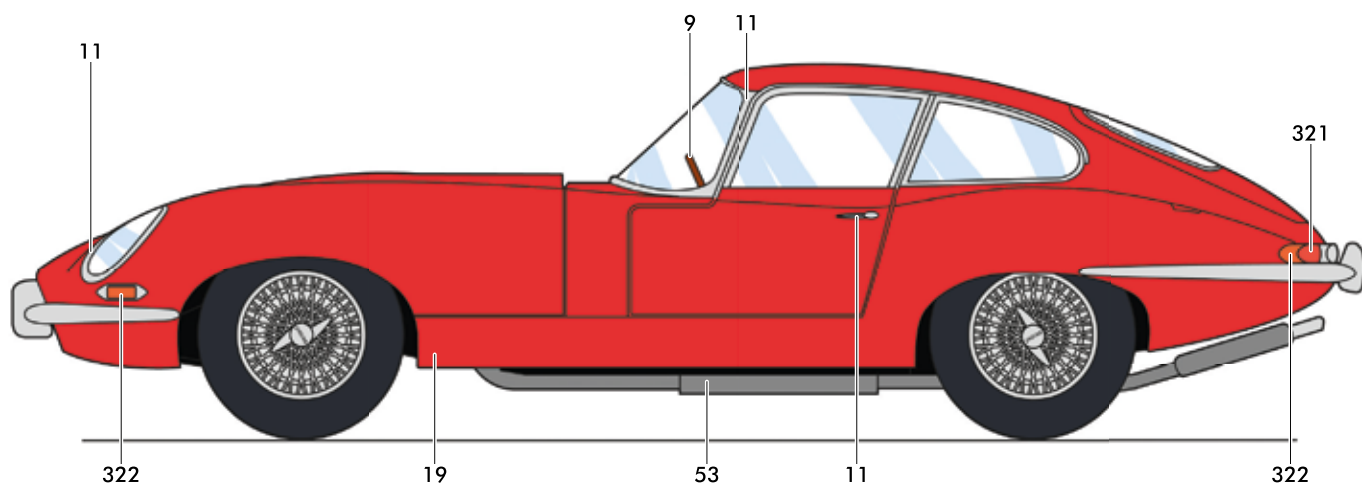
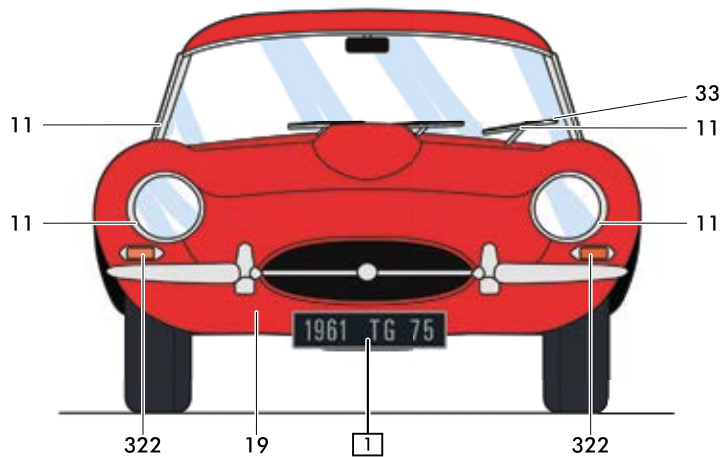

# VISITEZ-NOUS SUR LES RÉSEAUX SOCIAUX

VISIT US ON SOCIAL MEDIA!  
BESUCHEN SIE UNS AUF SOCIAL MEDIA!

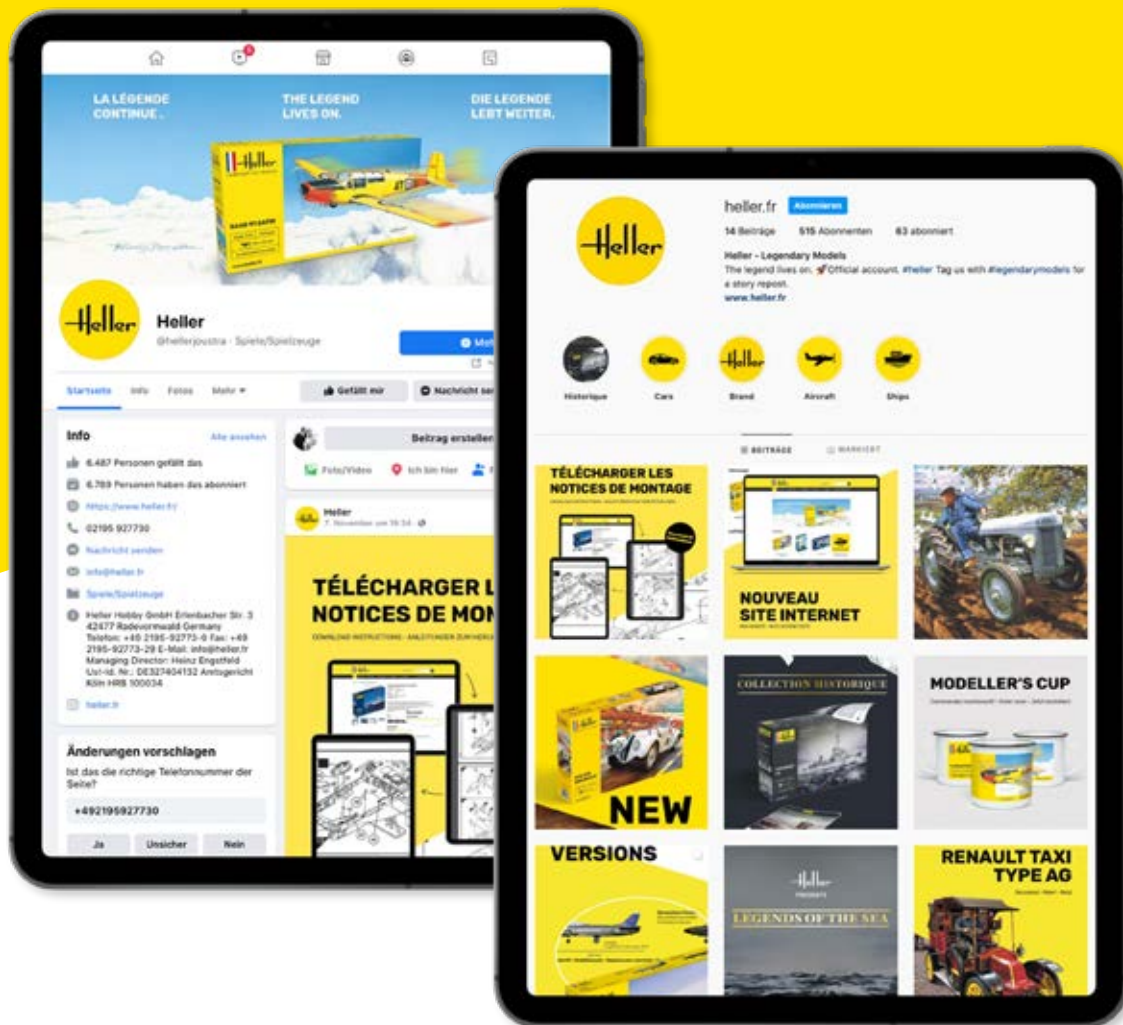

@instagram.com/heller.fr • facebook.com/heller.fr



# VISITEZ-NOUS EN LIGNE !

VISIT US DIGITALLY!  
BESUCHEN SIE UNS DIGITAL!

 [www.heller.fr](http://www.heller.fr)

 [instagram.com/heller.fr](https://www.instagram.com/heller.fr)

 [facebook.com/heller.fr](https://www.facebook.com/heller.fr)

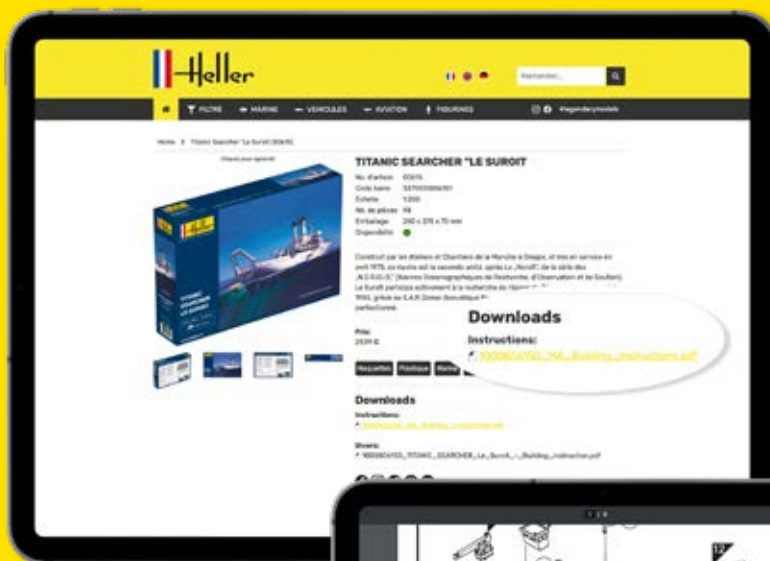

Choisissez l'article que vous désirez et téléchargez les instructions.  
Choose your desired article and download the instructions.  
Wählen Sie den gewünschten Artikel und laden Sie die Anleitung herunter.

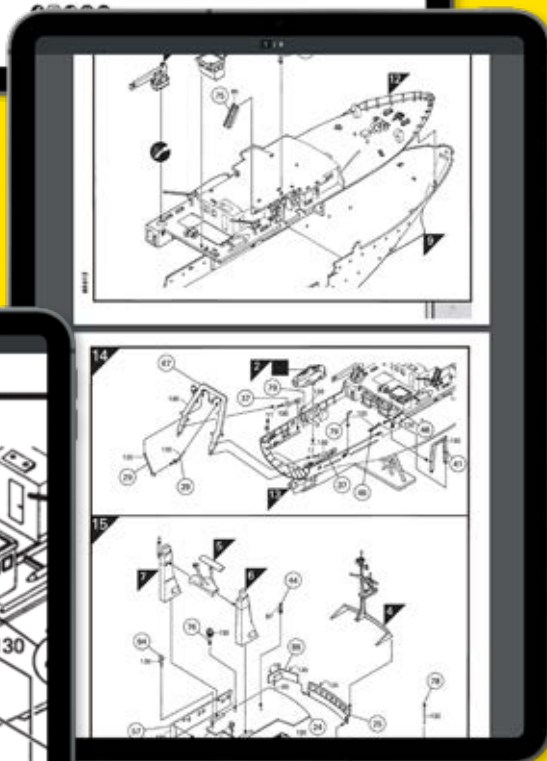

**Download all  
instructions!**

Grossissement des instructions pour  
une vue détaillée.

Enlarge the instructions for a more  
detailed view.

Vergrößern Sie die Anleitung für eine  
detailliertere Ansicht.

V-070421

**Service consommateurs**  
Pour toute demande de SAV, connectez-vous  
sur notre site [www.heller.fr](http://www.heller.fr).

**Customer Service**  
For after-sales service requests,  
please contact us through our website  
[www.heller.fr](http://www.heller.fr).

**Endverbraucherservice**  
Bitte besuchen Sie uns auf [www.heller.fr](http://www.heller.fr)  
für alle Ersatzteilanfragen.

**Heller Hobby GmbH**

Erlenbacher Str. 3 • 42477 Radevormwald • GERMANY

☎ +49 (0) 2195-92773-0 ✉ [info@heller.fr](mailto:info@heller.fr)