

FERGUSON "Petit Gris" TE-20/FF-30



81401

F

Harry Ferguson naquit en 1884 en Irlande. Passionné d'automobiles et d'aéroplanes, il fut le premier Irlandais à voler en 1909. Il distribua plus tard des automobiles et des tracteurs.

Il inventa en 1916 le Système Ferguson, un dispositif à 3 points conçu pour fixer les socs aux tracteurs, qui est devenu la norme aujourd'hui. Il en breveta une version améliorée en 1936. Cette même année, il commença à construire ses propres tracteurs, puis en partenariat avec Henry Ford dès 1939. Plus de 300.000 tracteurs Ford-Ferguson furent vendus jusqu'en 1947.

Le TE-20, surnommé Petit-Gris, fut lancé en 1946 et construit à Coventry par la Standard Motor Co (propriétaire de Triumph depuis 1945). Plus de 500.000 exemplaires, tant essence que Diesel, y furent construits jusqu'en 1956. Les TE-20 de Coventry furent importés en France dès 1946 et leur succès fut tel qu'un partenariat entre Standard Motor Co et Hotchkiss fut signé en 1953. L'usine de Saint-Denis assembla des TE-20 à partir de pièces britanniques importées. Cependant, la proportion de pièces françaises augmenta jusqu'à atteindre 100% en 1957, date à laquelle le TE-20 devint le FF-30. Le FF-30 était un TE-20 avec des différences mineures (forme du siège, emplacement de la batterie, moteur et châssis peints en rouge) et fut produit jusqu'en 1958. Quelque 50.000 tracteurs sortirent de l'usine de Saint-Denis.

GB

Harry Ferguson was born 1884 Ireland. He was fond of automobiles and aeroplanes and became the first Irishman to fly in 1909. He later founded a company selling cars and tractors.

In 1916 he invented the Ferguson System, a 3-point linkage designed to attach ploughs to tractors that is the norm nowadays. He patented an improved version of it in 1936. He then started building tractors, first on his own, then from 1939 in partnership with Henry Ford. Over 300,000 Ford-Fergusons were sold until 1947.

The TE-20, nicknamed Little Grey Fergie, was launched in 1946 and built in Coventry by the Standard Motor Co (which had owned Triumph since 1945). More than 500,000 units, both petrol and Diesel, were built until 1956. Coventry-built TE-20s were imported in France from 1946 and were successful enough to justify a joint-venture between Standard Motor Co and Hotchkiss in 1953. TE-20s would be assembled in the Saint-Denis factory, mostly from imported British parts. The share of French-built parts increased until reaching 100% in 1957 when the TE-20 became the FF-30. The FF-30 was a TE-20 with minor differences (seat shape, battery location, red-painted engine and chassis) and was produced until 1958. Some 50,000 tractors were built in Saint-Denis.

D

Harry Ferguson wurde in 1884 in Irland geboren. Er war sehr begeistert von Automobilen und Flugzeugen und war der erste Irländer der in 1909 einen Flug realisiert hat. Danach hat er eine Gesellschaft gegründet die Automobile und Traktoren verkauft hat.

In 1916 hat er das 'Ferguson' System erfunden, ein 3-Festpunktsystem, dass heute die Norm ist. In 1936 hat er eine bessere Version patentiert. Ab dann baute er seine eigene Traktoren, und ab 1939 in Zusammenarbeit mit Henry Ford. Bis 1947 wurden über 300.000 Traktoren verkauft. Der TE-20, der 'kleine graue', wurde ab 1946 gebaut in Coventry von der 'Standard Motor Company', die seit 1945 Eigentümerin von Triumph war. Bis 1956 wurden mehr als 500.000 Exemplare gebaut, sowohl Diesel als Benzin. Der TE-20 von Coventry wurden ab 1946 in Frankreich importiert und deren Erfolg resultierte in einer Zusammenarbeit zwischen Standard Motor Co und Hotchkiss ab 1953. Die Fabrik in Saint-Denis verarbeitete dann die aus Groß-Britannien importierten TE-20-Unterteile. Der Anteil von französischen Unterteilen stieg bis 100% in 1957. Ab dann wurde der TE-20 FF-30. Der FF-30 war ein TE-20 mit kleinen Änderungen (die Form der Sitze, Lagerung der Batterie, Motor und Chassis rotgefärbt). Die Produktion lief bis 1958. Es sind 50.000 Traktoren vom Band gelaufen in der Fabrik von Saint-Denis.

E

Harry Ferguson nació en Irlanda en 1884. Apasionado de automóviles y aviones, fue el primer irlandés a volar en 1909. Más tarde, distribuyó automóviles y tractores.





Inventó en 1916 el Sistema Ferguson, un dispositivo de 3 puntos concebido para fijar las rejas a los tractores, que hoy en día usan todos los tractores. Patentó una versión mejorada en 1936. Este mismo año, empezó a construir sus propios tractores, y luego en asociación con Henry Ford desde 1939. Se vendieron más de 300.000 tractores Ford-Ferguson hasta 1947. El TE-20, también llamado Pequeño Gris, fue lanzado en 1946 y construido en Coventry por la Standard Motor Co (propietario de Triumph desde 1945). Más de 500.000 ejemplares, tanto de gasolina como Diésel, fueron construidos allí hasta 1956. Los TE-20 de Coventry se importaron a Francia desde 1946 y tal fue su éxito que Standard Motor Co se asoció con Hotchkiss en 1953. La fábrica Saint-Denis ensambló los TE-20 con piezas británicas importadas. Sin embargo, el porcentaje de piezas francesas aumentó hasta alcanzar un 100% en 1957, fecha cuando el TE-20 se convirtió en el FF-30. El FF-30 era un TE-20 con diferencias menores (forma del asiento, ubicación de la batería, motor y chasis pintados de rojo) y fue producido hasta 1958. Unos 50.000 tractores salieron de la fábrica de Saint-Denis.

1 Numéro de phase
Step number
Schrittnummer
Número de fase

A1 Numéro de pièce
Part number
Teilenummer
Número de pieza

11 Référence de couleur
Colour reference no
Farbangabe
Referencia de color

PEINTURES ESSENTIELLES / ESSENTIAL PAINTS / PINTURAS ESENCIALES / NOTWENDIGE FARBEN

					
19	40	11	33	66	40/19
Rouge vif brillant Bright gloss red Glänzendes knallrot Rojo claro brillante	Gris pâle brillant Pale gloss grey Glänzendes hellgrau Gris claro brillante	Argent Silver Silber Plata	Noir mat Matt black Mattes Schwarz Negro mate	Gris brun olive mat Matt olive grey brown Braun-grau matte olivenfarbe Gris marrón aceituna mate	TE-20: 40 FF-30: 19

PEINTURE DISPONIBLE SÉPARÉMENT CHEZ VOTRE REVENDEUR DE MAQUETTES. WWW.HELLER.FR
PINTURAS DISPONIBLES EN SU TIENDA DE MODELISMO

PAINT AVAILABLE SEPARATELY FROM YOUR HOBBY STORE
DIE FARBEN SIND SEPARAT IN IHREM HOBBYGESCHÄFT ZU KAUFEN

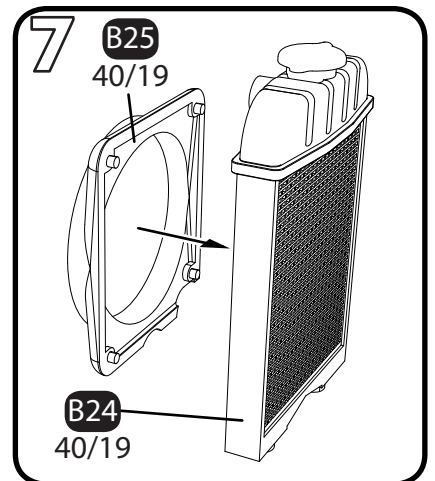
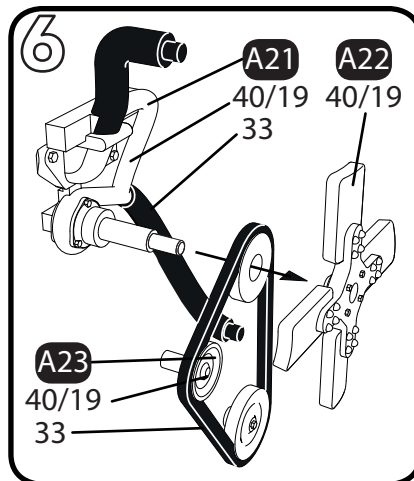
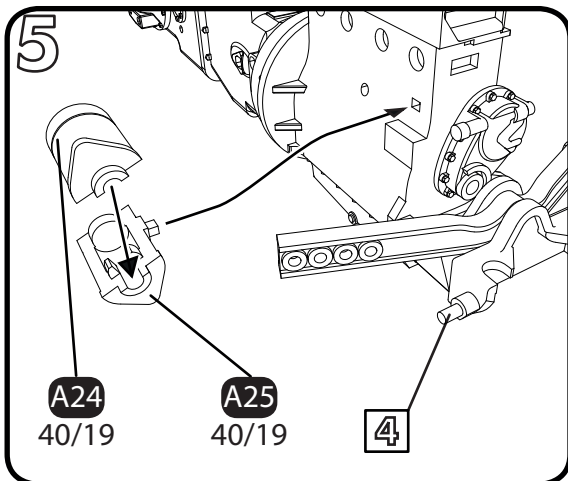
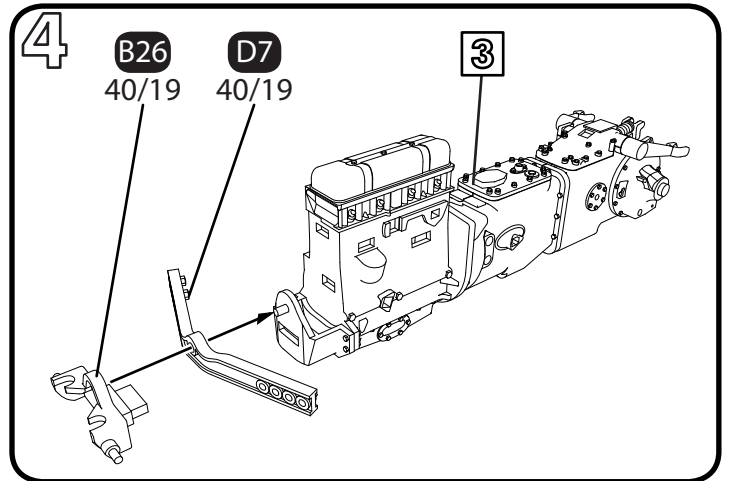
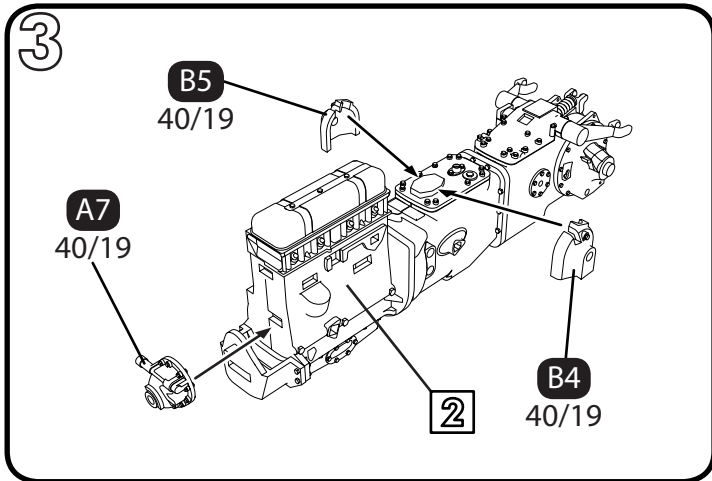
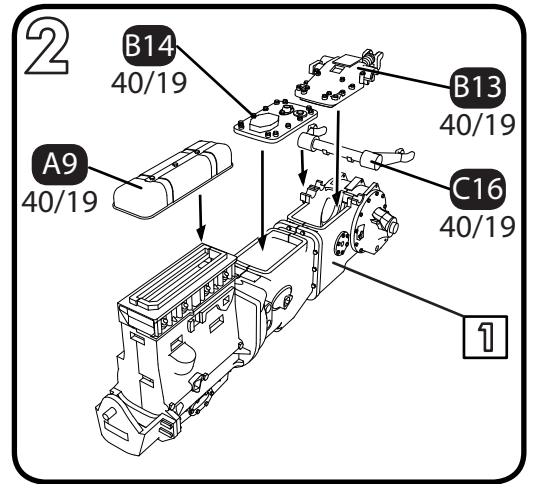
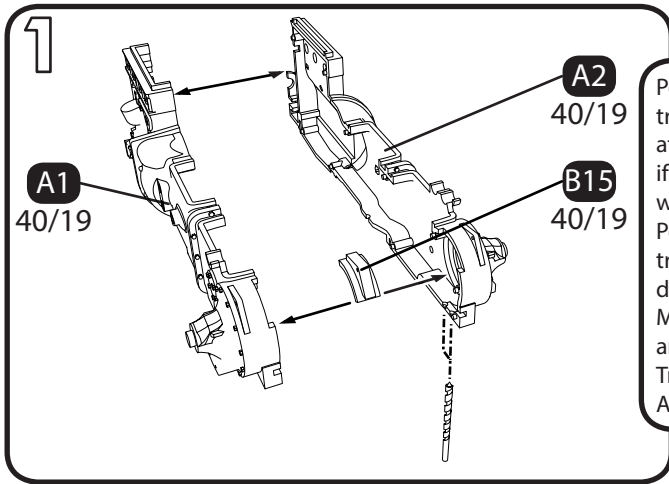

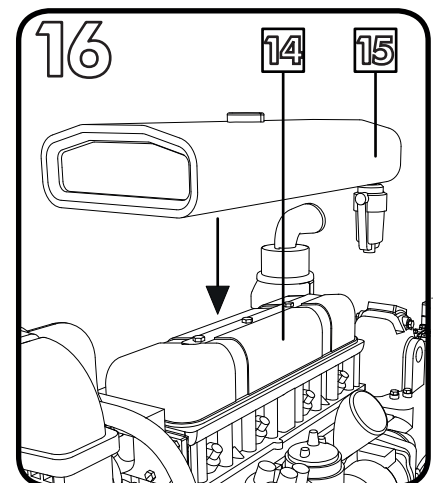
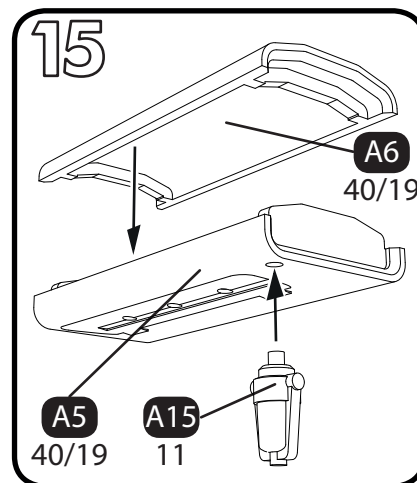
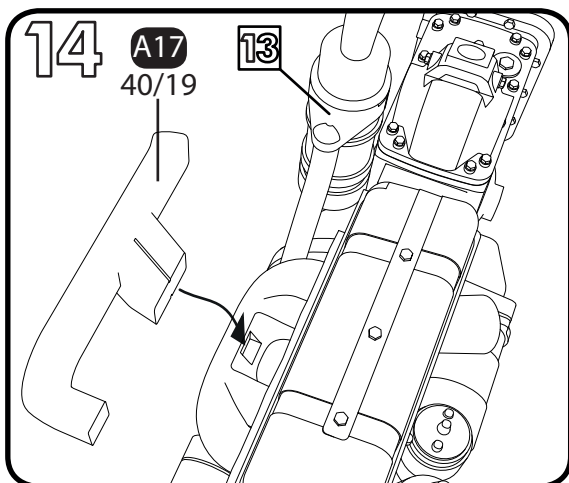
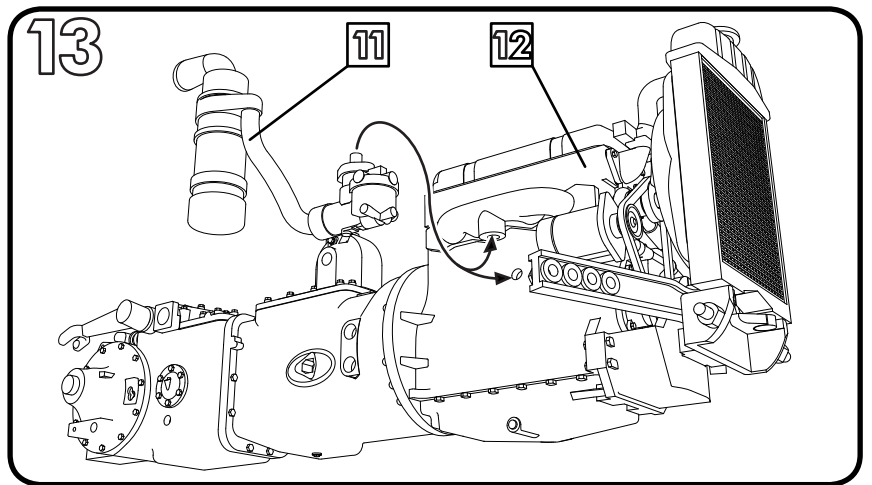
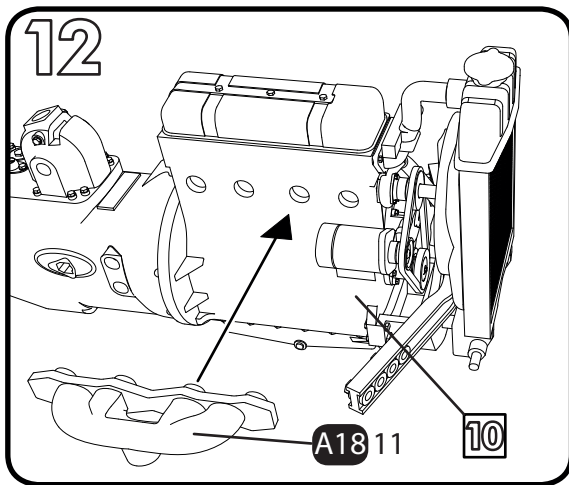
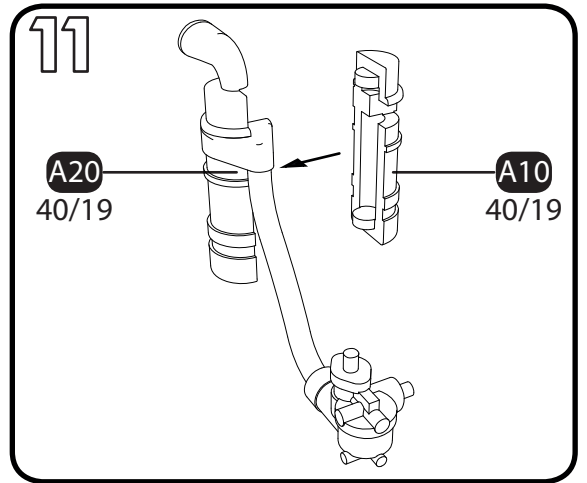
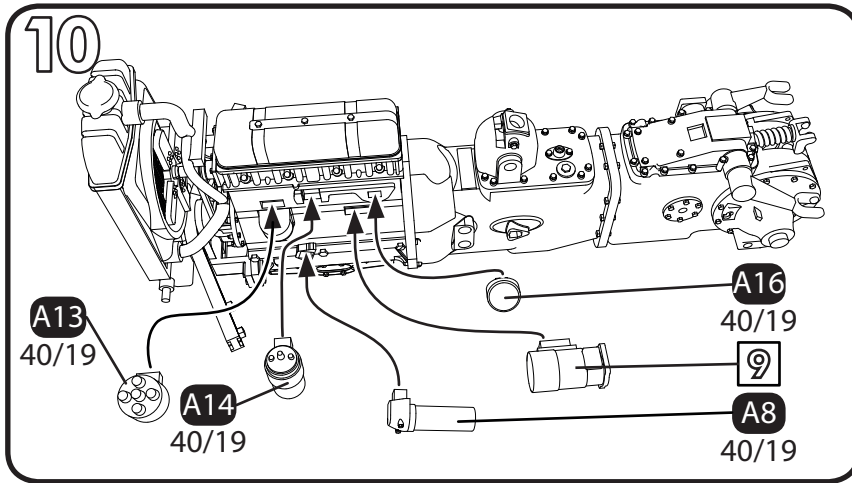
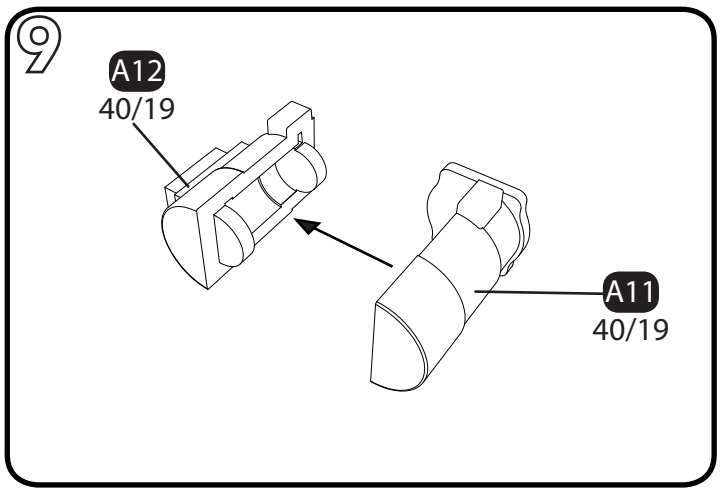
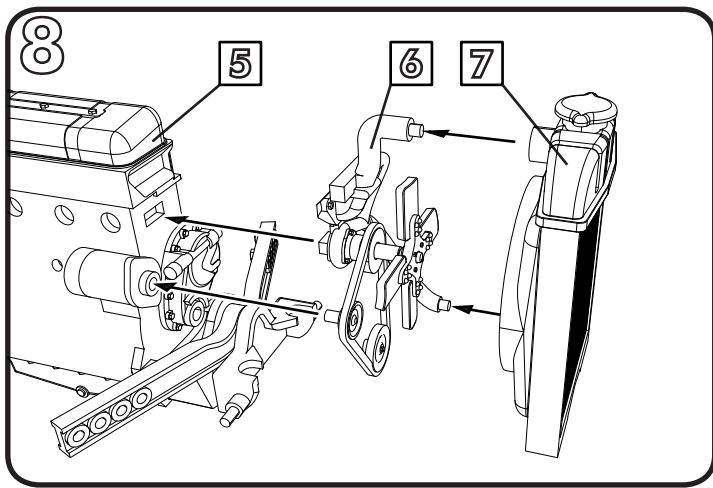

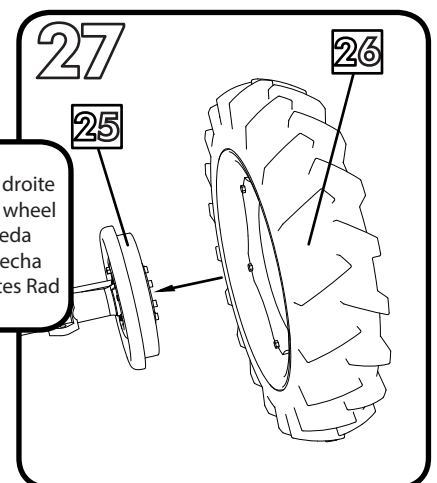
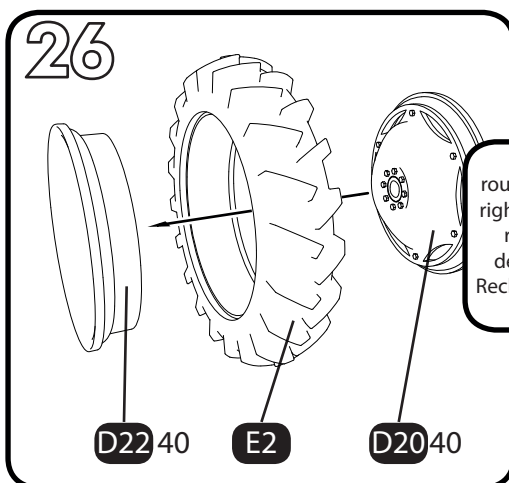
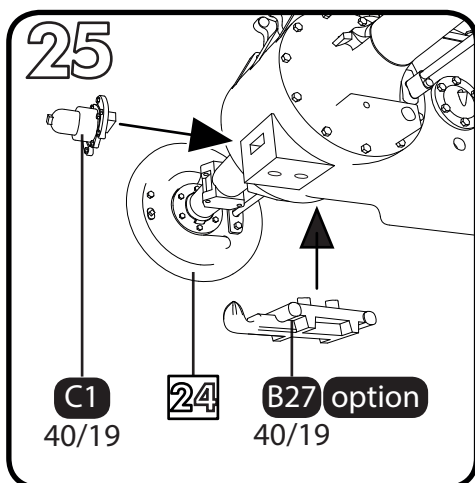
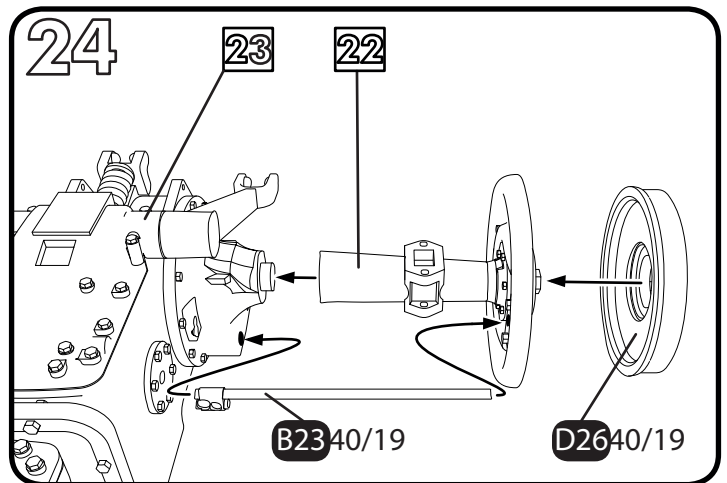
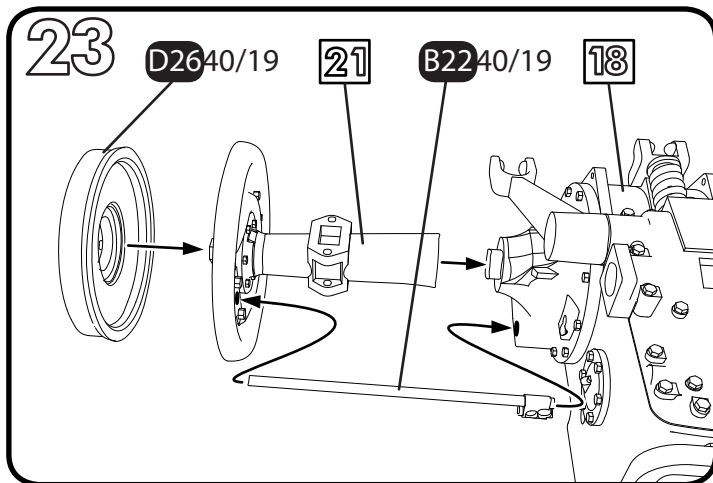
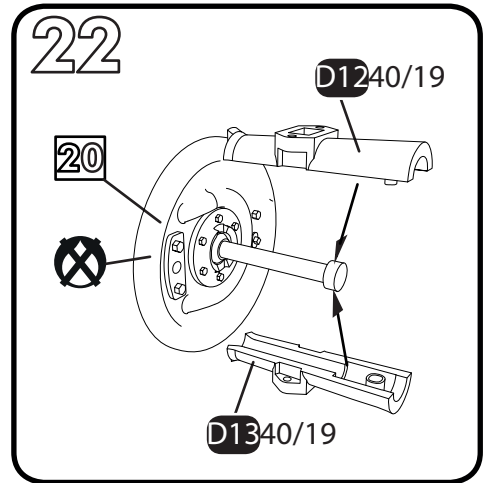
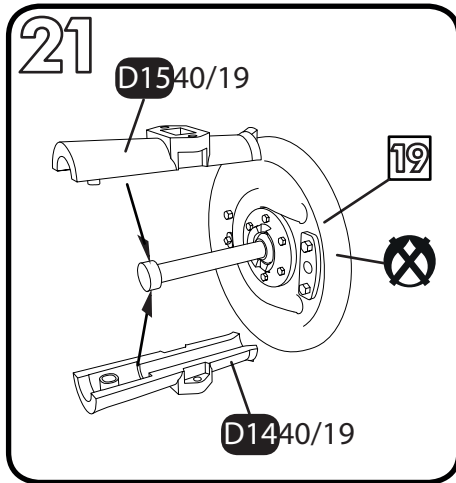
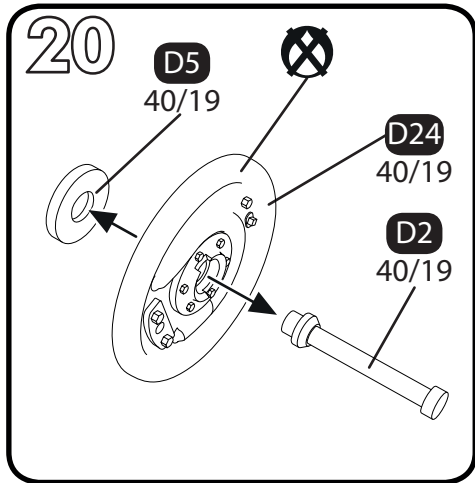
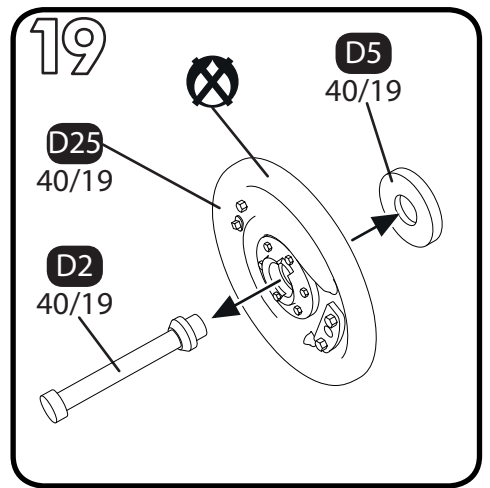
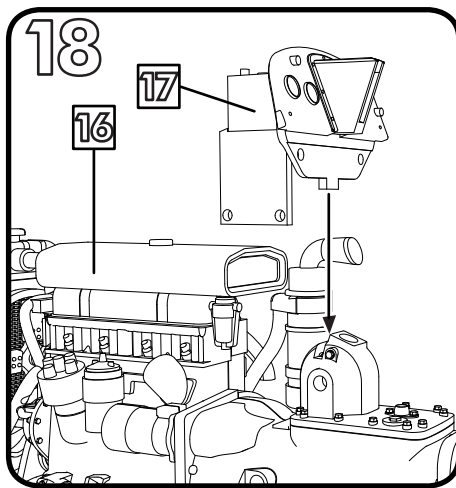
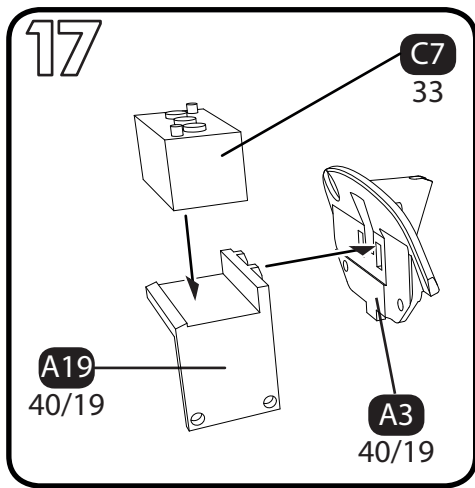

roue droite
right wheel
rueda
derecha
Rechtes Rad

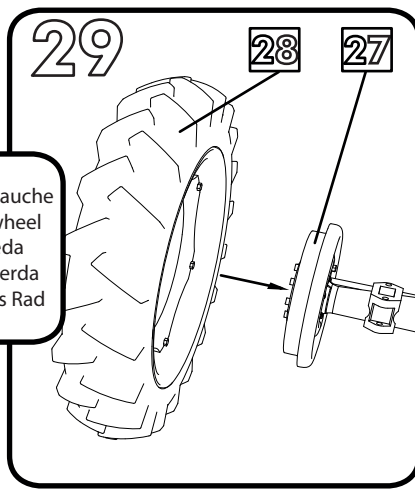
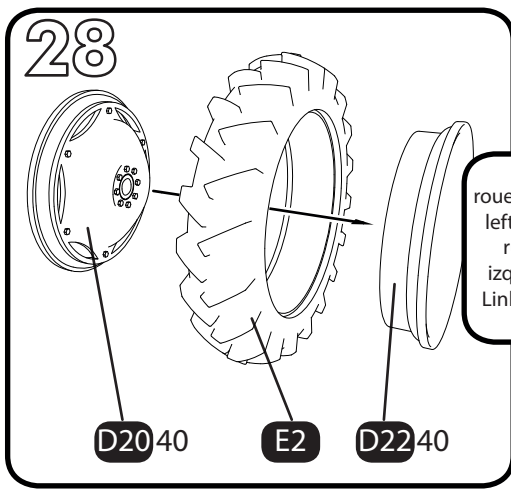

roue gauche
left wheel
rueda
izquierda
Linkes Rad

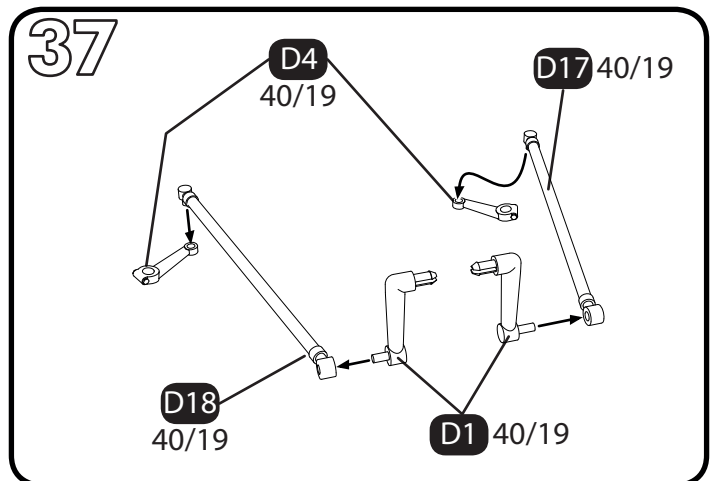
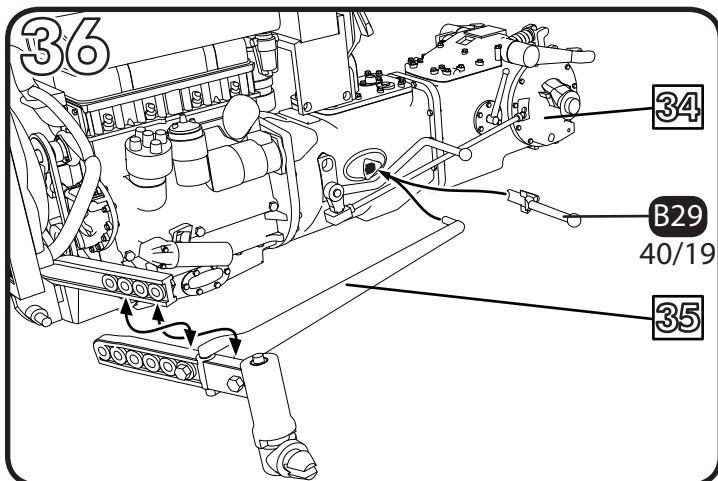
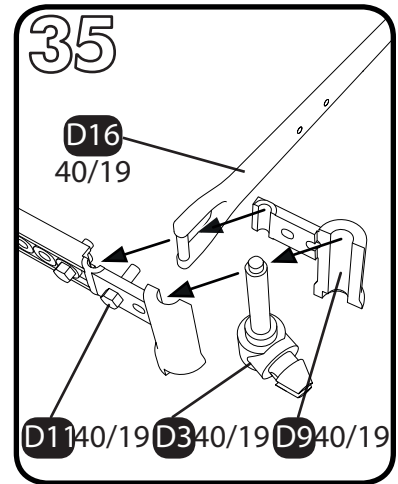
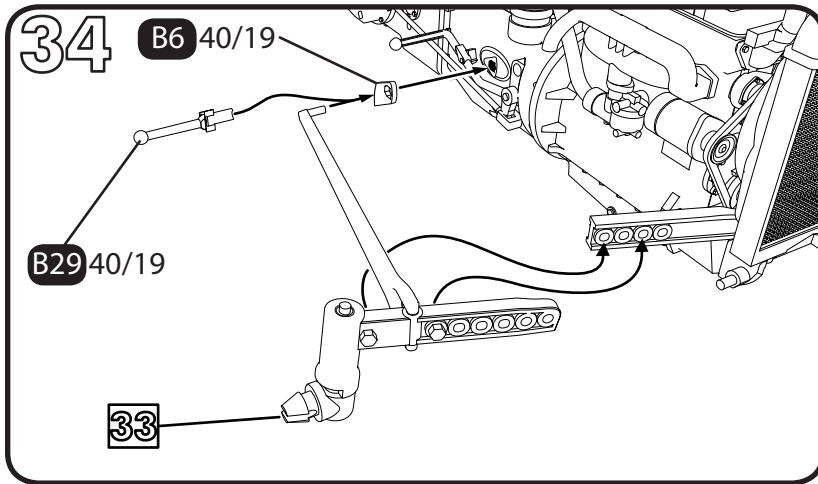
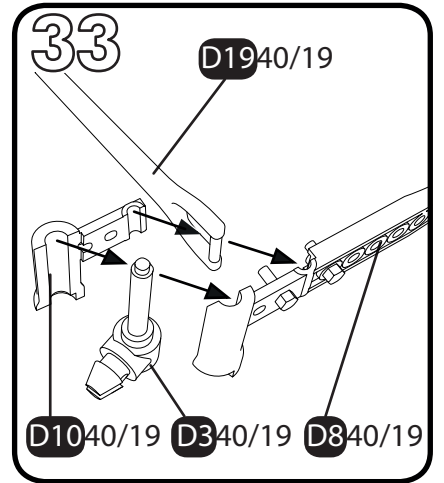
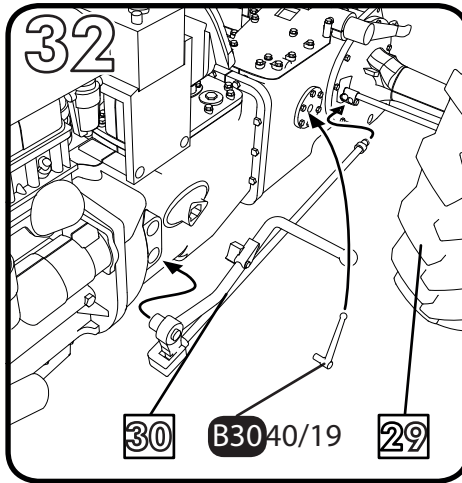
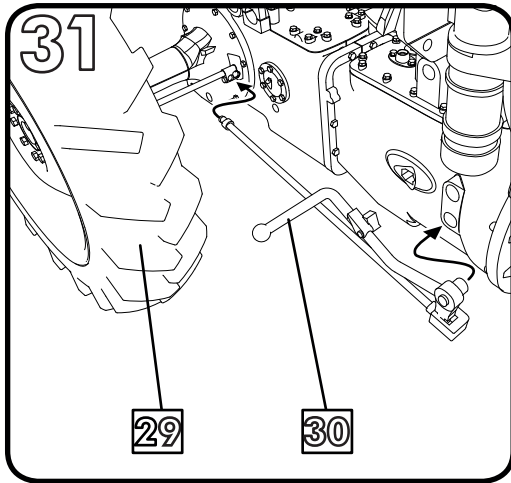
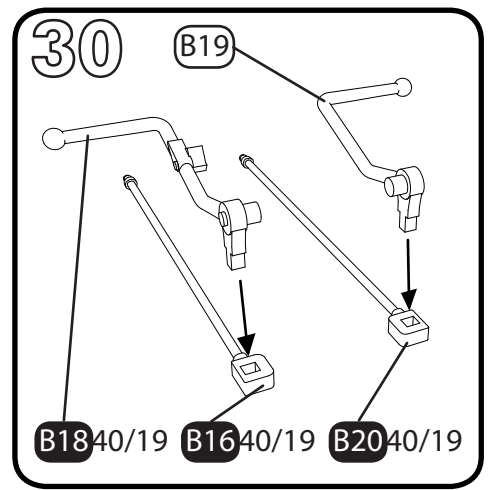

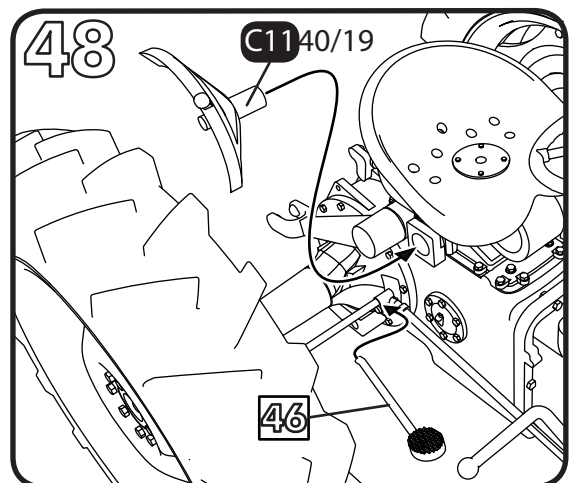
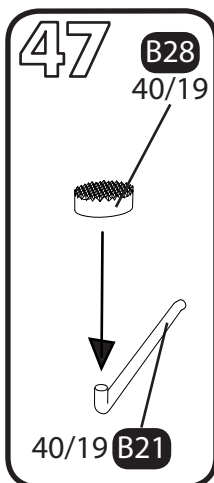
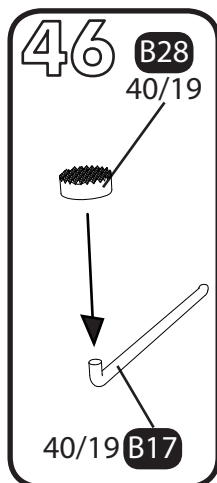
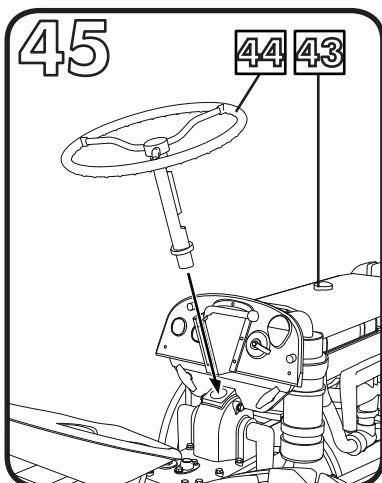
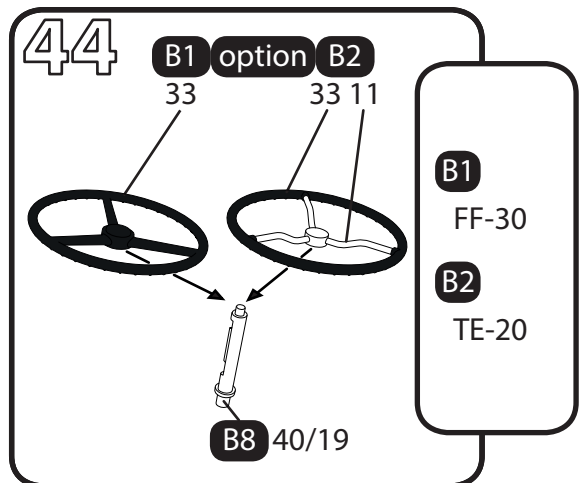
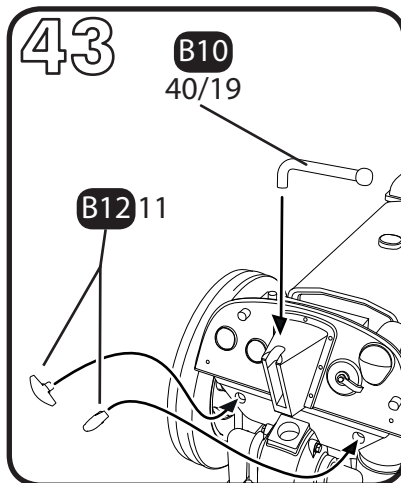
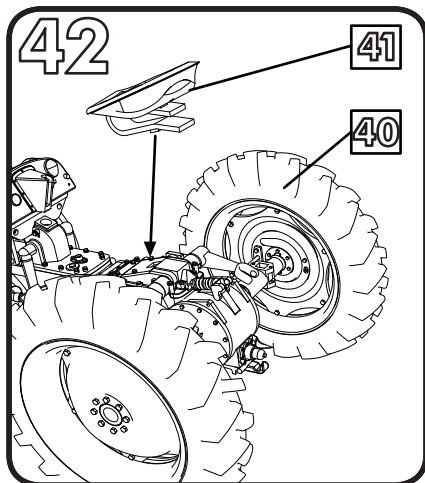
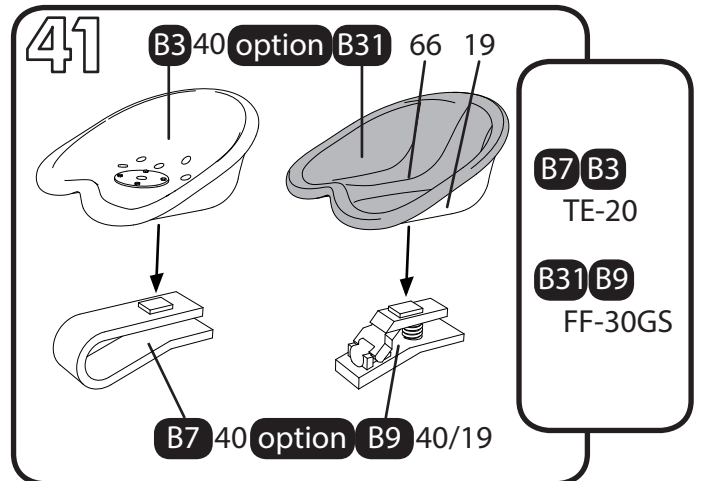
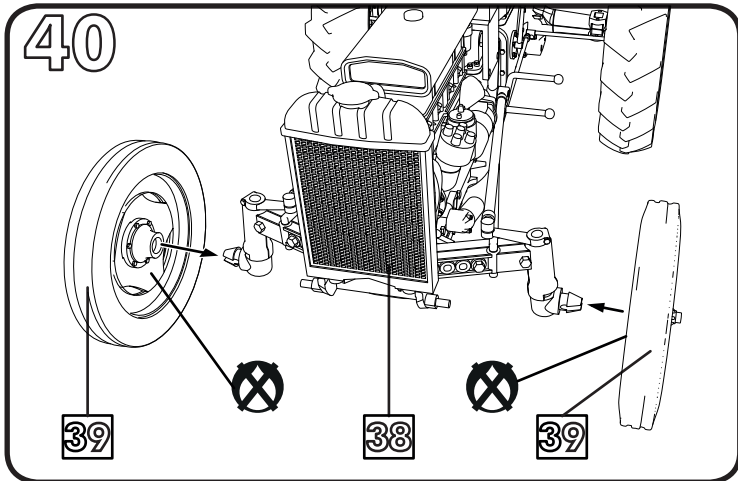
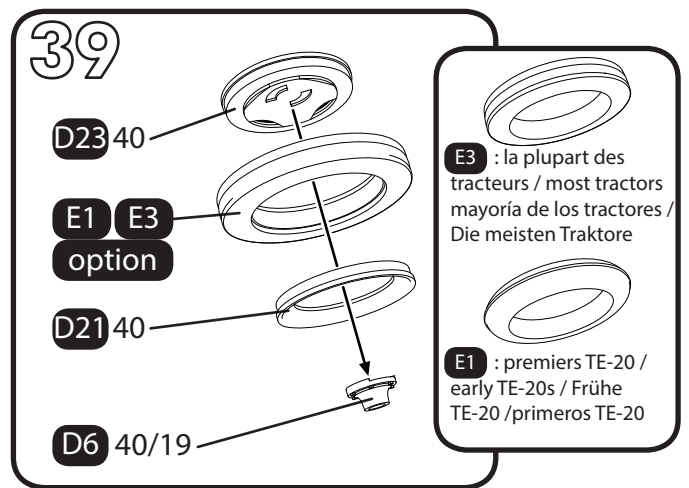
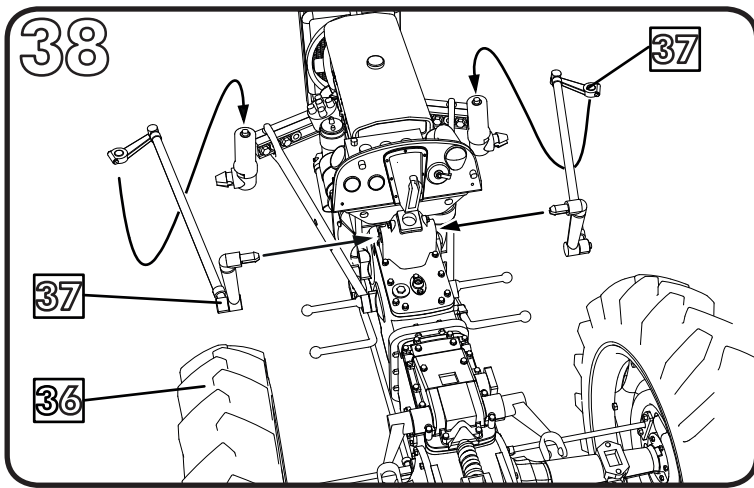

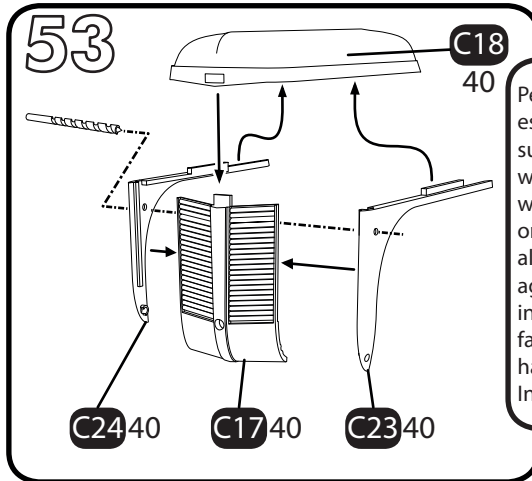
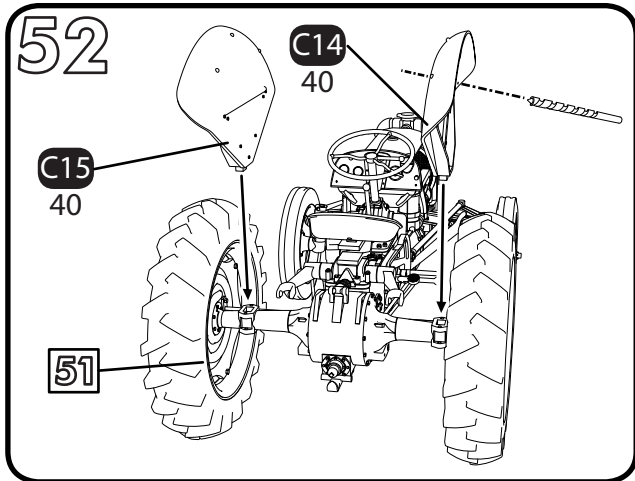
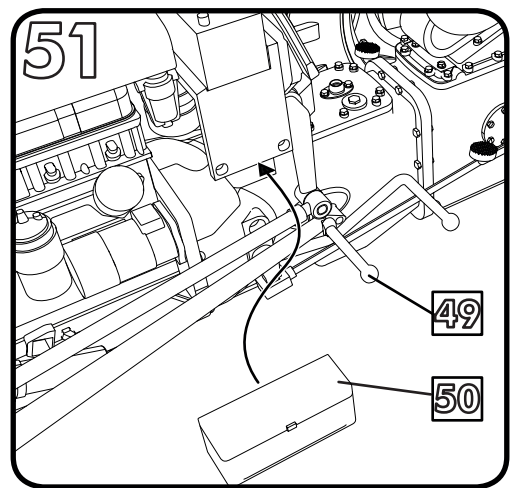
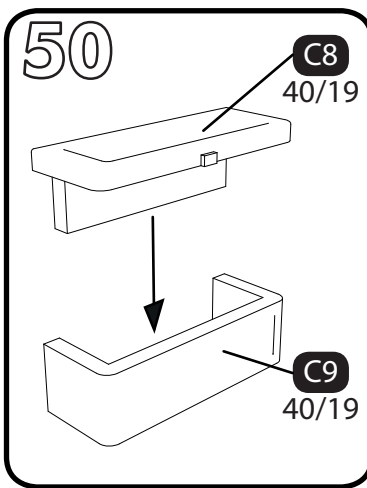
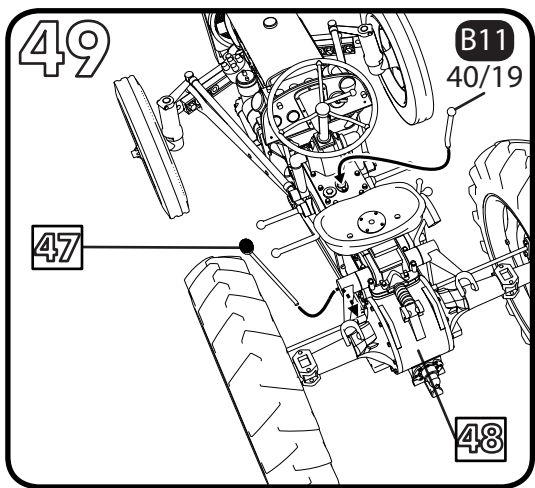

Perçer les ailes si le tracteur est doté de phares - pré-trou sur la face intérieure / Drill wings if tractor equipped with headlights - pilot hole on inner side / Perforar las alas si el tractor tiene faros - agujero-guía en la cara interior / Die Flügel anbohren falls der Traktor Scheinwerfer hat - Lochangabe an der Innenseite

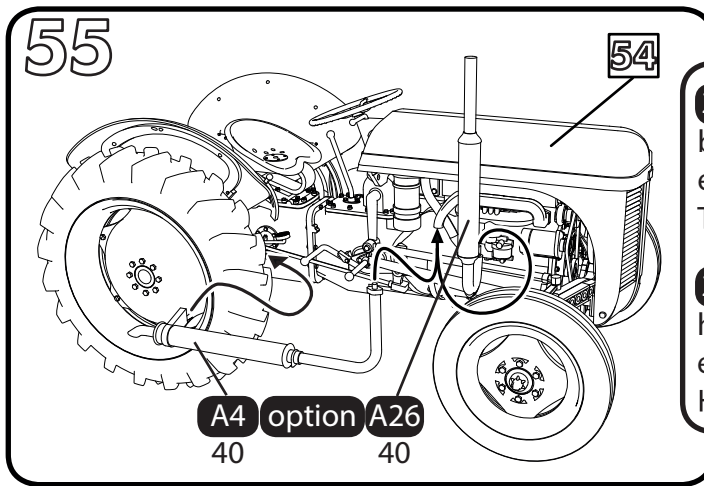
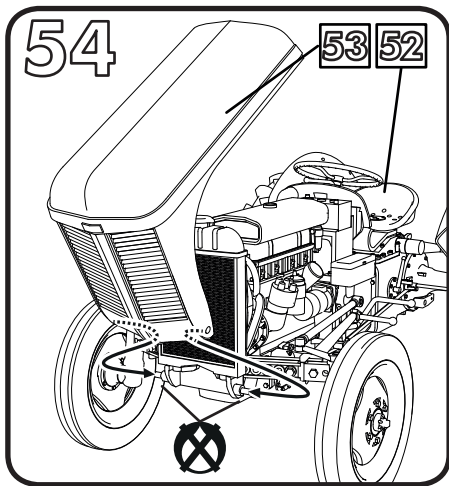

225 Échappement bas / low exhaust / escape bajo / Tiefer Auspuff
25 Échappement haut / high exhaust / escape alto / Hoher Auspuff

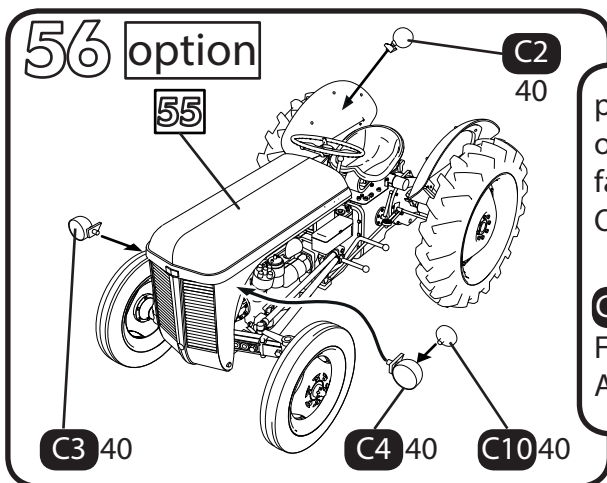

phares optionnels / optional headlights / faros opcionales / Optionale Scheinwerfer.
C10 FF-30 seulement / FF-30 only / sólo FF-30 / Ausschließlich FF-30.

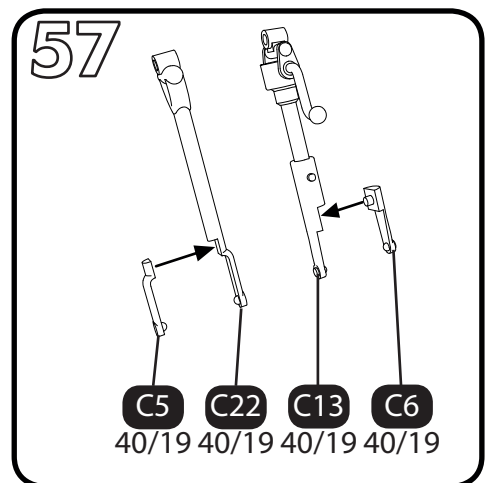

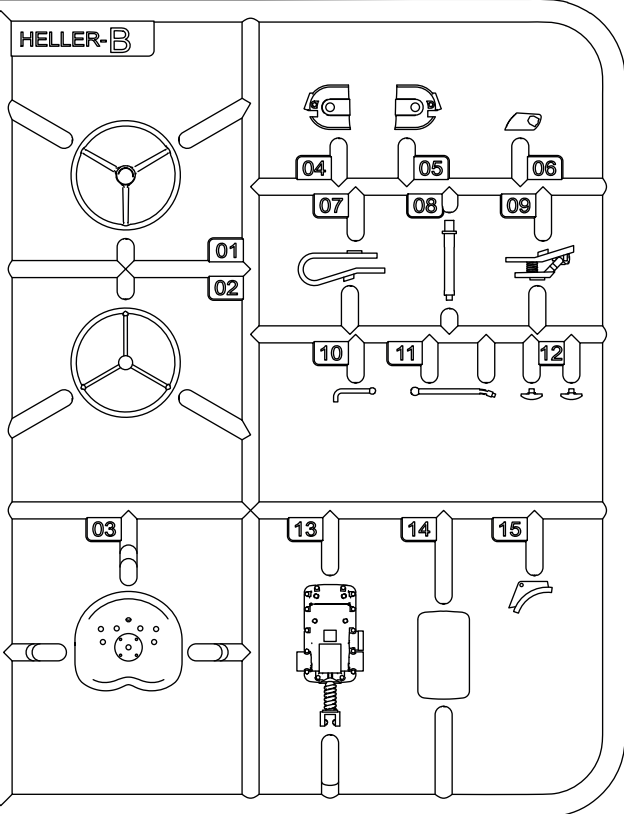
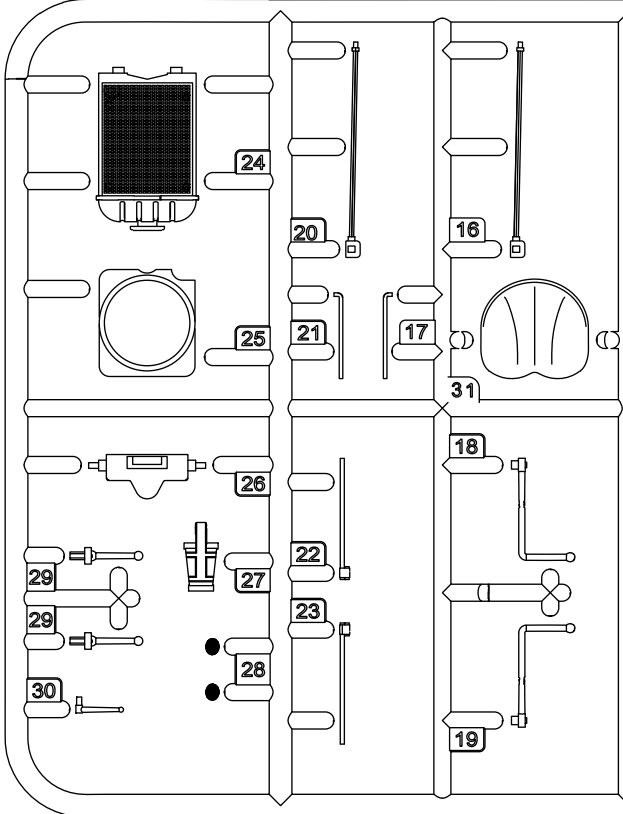
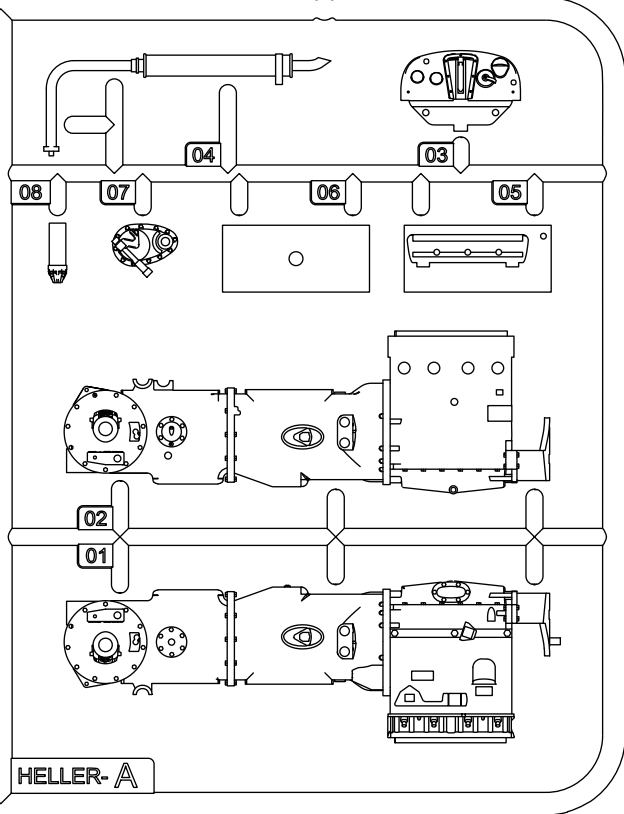
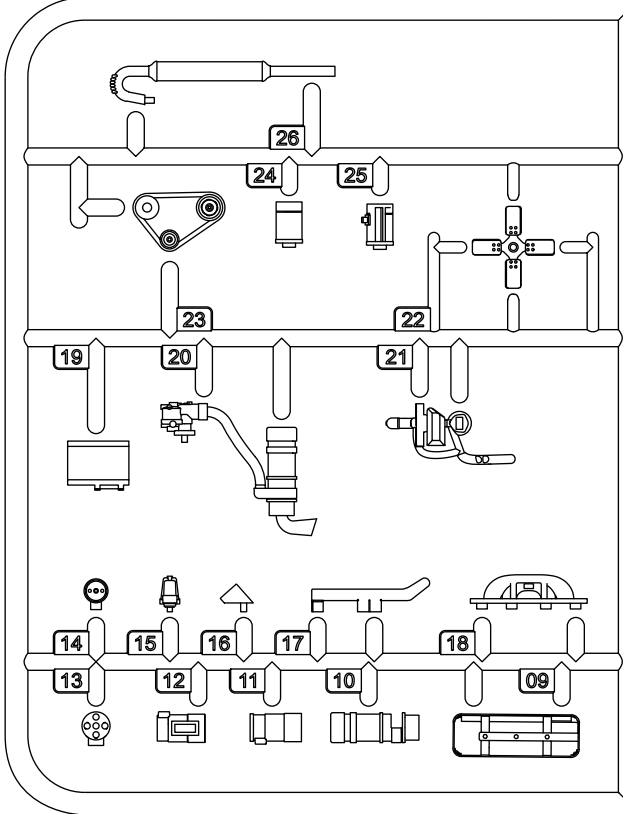
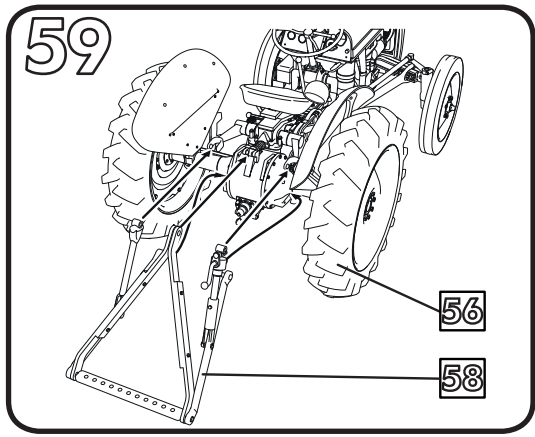
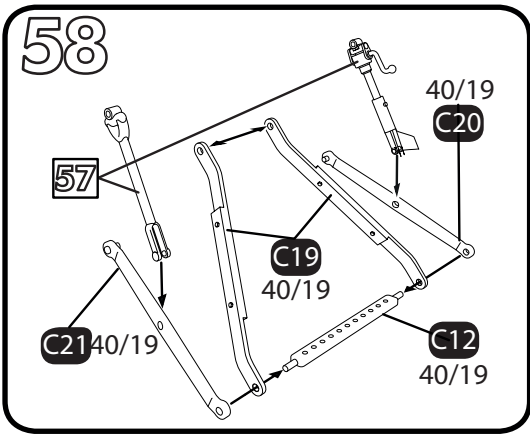

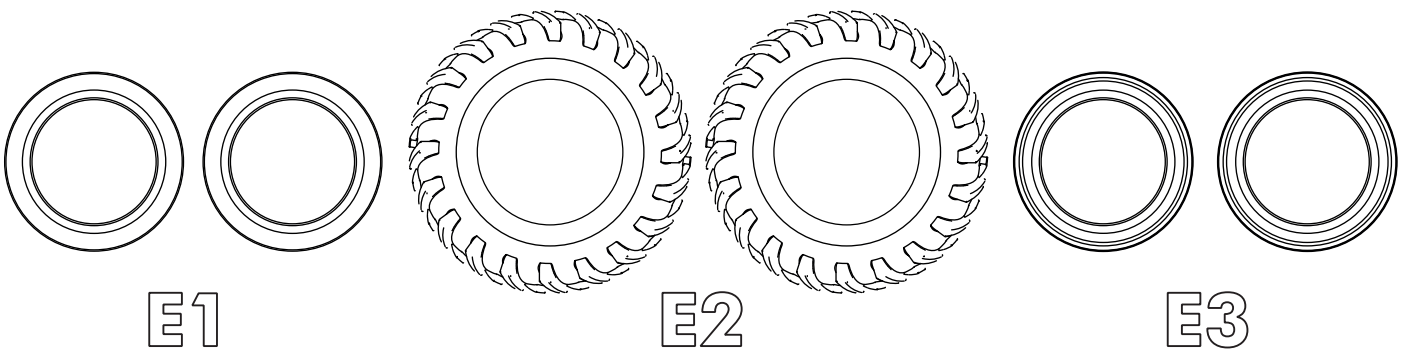
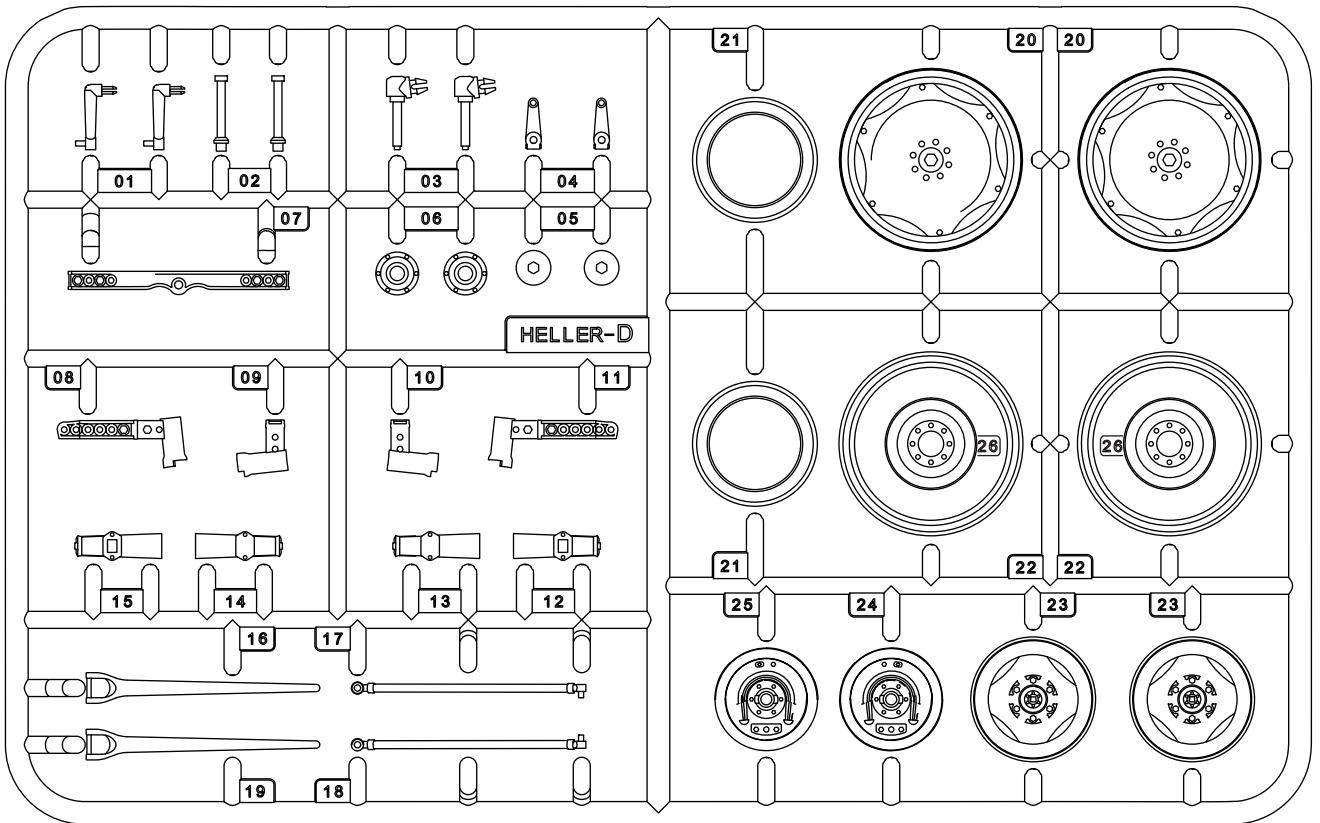
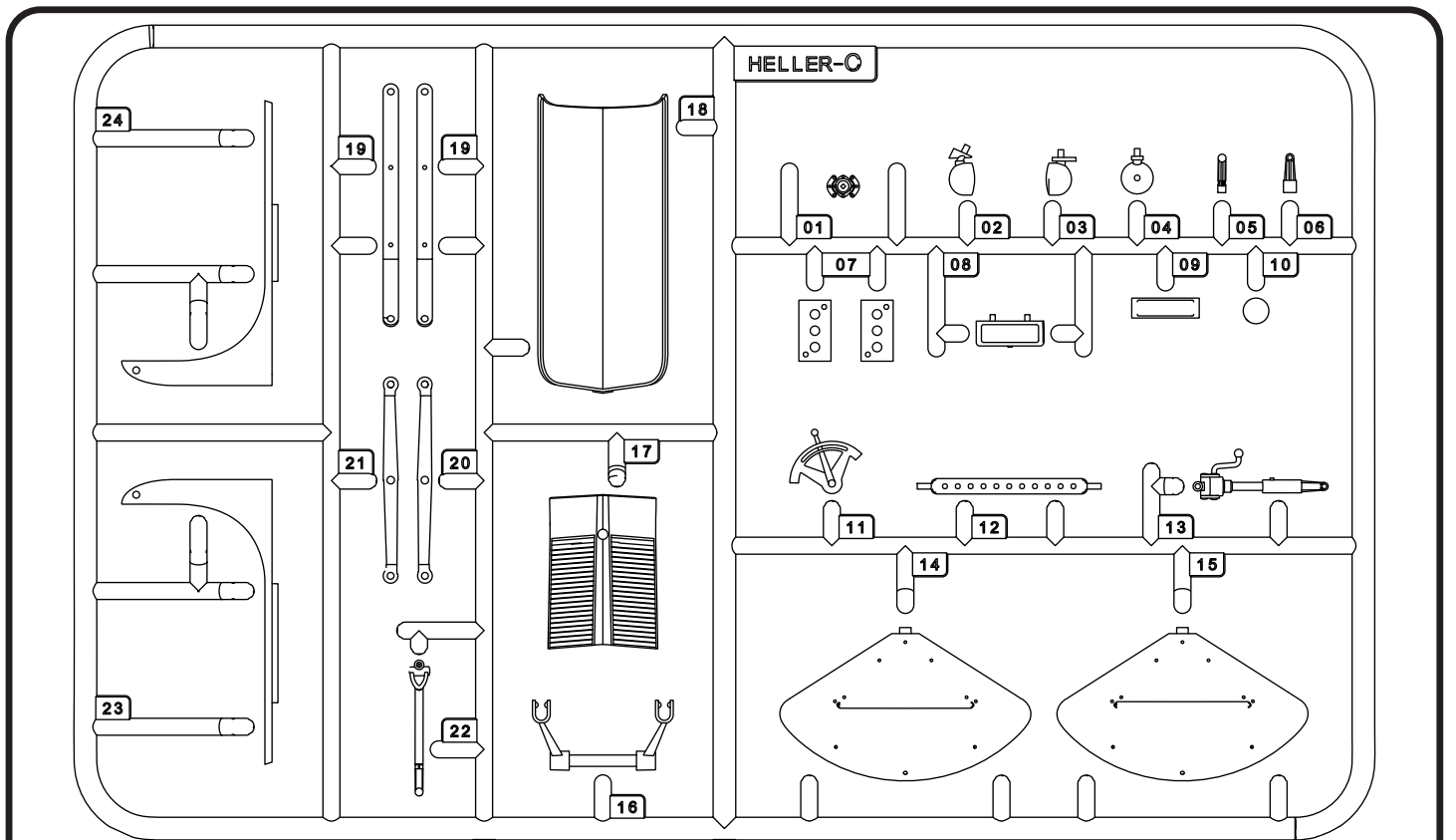

PEINTURES ESSENTIELLES / ESSENTIAL PAINTS / PINTURAS ESENCIALES / NOTWENDIGE FARBEN



40
Gris pâle brillant
Pale gloss grey
Glänzendes hellgrau
Gris claro brillante



11
Argent
Silver
Silber
Plata



33
Noir mat
Matt black
Mattes Schwarz
Negro mate

PEINTURE DISPONIBLE SÉPARÉMENT CHEZ VOTRE REVENDEUR DE MAQUETTES. WWW.HELLER.FR

PAINT AVAILABLE SEPARATELY FROM YOUR HOBBY STORE

PINTURAS DISPONIBLES EN SU TIENDA DE MODELISMO

DIE FARBEN SIND SEPARAT IN IHREM HOBBYGESCHÄFT ZU KAUFEN

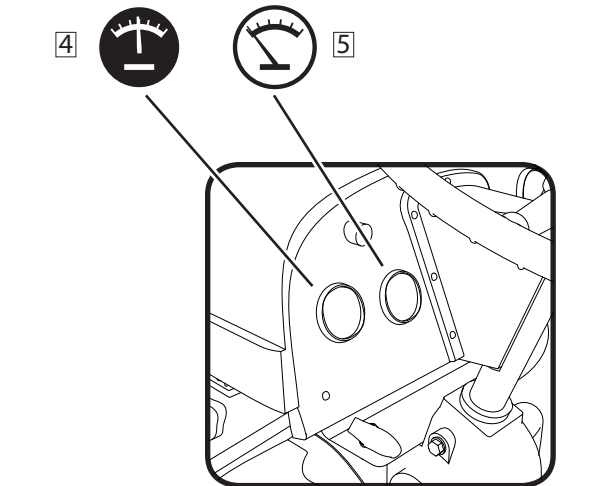
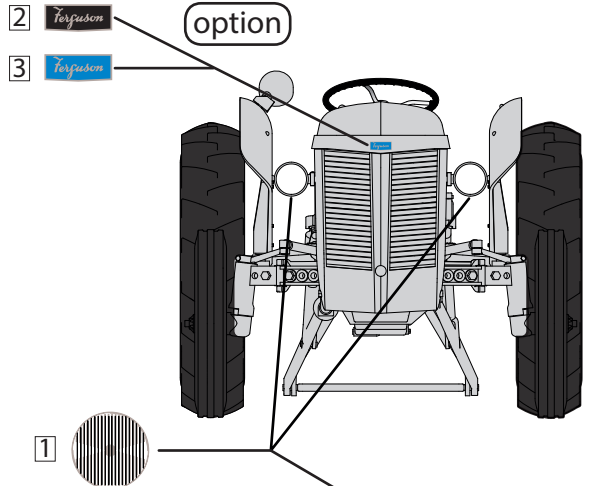
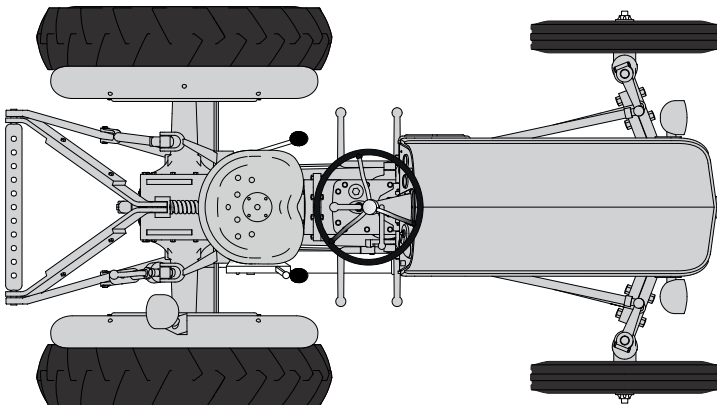
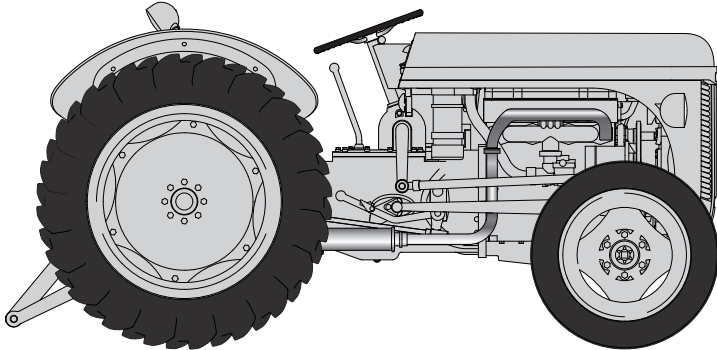
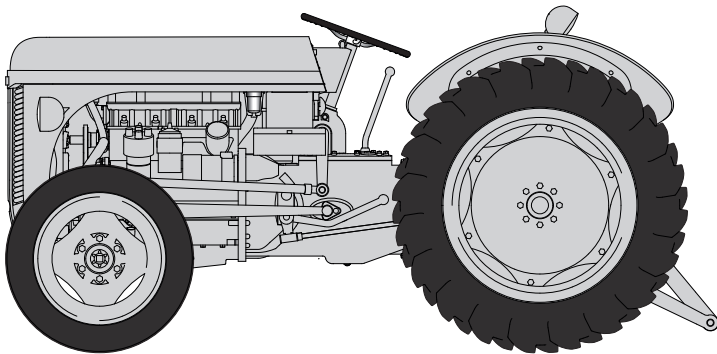

PEINTURES ESSENTIELLES / ESSENTIAL PAINTS / PINTURAS ESENCIALES / NOTWENDIGE FARBEN

19
Rouge vif brillant
Bright gloss red
Glänzendes knallrot
Rojo claro brillante

40
Gris pâle brillant
Pale gloss grey
Glänzendes hellgrau
Gris claro brillante

11
Argent
Silver
Silber
Plata

33
Noir mat
Matt black
Mattes Schwarz
Negro mate

66
Gris brun olive mat
Matt olive grey brown
Braun-grau matte olivenfarbe
Gris marrón aceituna mate

PEINTURE DISPONIBLE SÉPARÉMENT CHEZ VOTRE REVENDEUR DE MAQUETTES. WWW.HELLER.FR

PAINT AVAILABLE SEPARATELY FROM YOUR HOBBY STORE

PINTURAS DISPONIBLES EN SU TIENDA DE MODELISMO

DIE FARBEN SIND SEPARAT IN IHREM HOBBYGESCHÄFT ZU KAUFEN

